

GF40/GF80

Thermal Mass Flow

Elastomer and Metal Seal Digital Mass Flow Controllers and Meters



Overview

Brooks GF40 (elastomer seals) and GF80 (all-metal) thermal mass flow controllers (MFCs) and thermal mass flow meters (MFMs) achieve unprecedented performance, reliability, and flexibility in many gas flow measurement and control applications.

At the heart of the GF40/GF80 is Brooks' patented 4th generation MultiFlo™ gas and range programmability. MultiFlo overcomes a long-standing limitation of many thermal MFCs – when changing gas types, a simple correction factor, such as the ratio of heat capacities between the calibration gas and new gas, cannot account for accuracy-robbing viscosity and density differences. The Brooks MultiFlo database is built on thousands of native gas runs to establish correction factors that account for both thermal and physical differences among gases making the GF40/GF80 Series among the most flexible MFCs/MFMs available today.

The Brooks GF40/GF80 Series is the perfect choice for customers who use thermal mass flow controllers or thermal mass flow meters on a variety of gases, who need to change gas type frequently, or who need to re-range while preserving gas measurement and control accuracy. Some examples:

- OEMs will reduce the number of gas- and range-specific MFCs that they inventory
- Solar, biotech, CVD, plasma, glass, web coating, nanotechnology, vacuum processing and similar large users of mass flow meters and mass flow controllers will greatly reduce their gas- and range-specific spares inventory
- R&D, research, and laboratory users can quickly change experiment conditions

MultiFlo programming is simple and fast – a new gas and range can be programmed under 30 seconds plus the device can be programmed without removing it from service or disconnecting the device from any process or tool control system.

Product Description

The Brooks GF40/GF80 Series features a corrosion-resistant Hastelloy C-22 sensor for durable, long-term operation. Sub-1 second settling times and 1% full scale accuracy ensure that the GF40/GF80 will provide reliable flow measurement or flow control in demanding gas flow applications. Both GF40 and GF80 achieve excellent internal to external leak integrity for challenging process gases as found in CVD, solar, and other processes. With a wide range of connector types, seal and seat materials, and digital and analog I/O options available, the GF40/GF80 represents an extremely powerful, yet easy, upgrade for existing MFCs or MFMs.

Features and Benefits

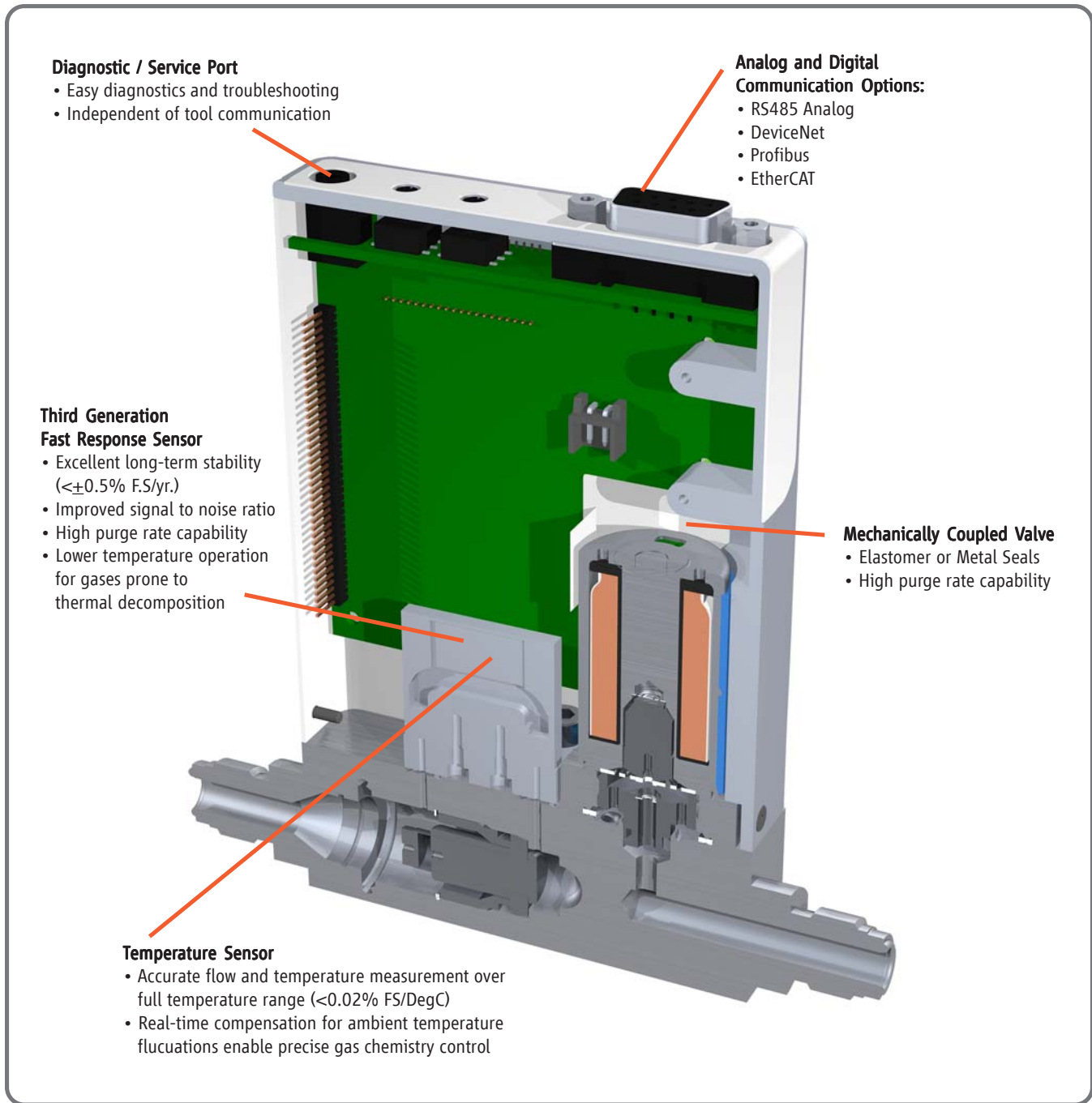

Features	Benefits
Elastomer or Metal seal	Cost performance flexibility for a wide range of applications.
MultiFlo Gas and Range Programmability with Advanced Diagnostics and User Accessible Service Port	Select new gas calibrations and full-scale ranges without the trouble and cost of removing the mass flow controller from the gas line. Convenient interface to diagnostics port for maximum uptime.
Corrosion Resistant Hastelloy Sensor	Provides unmatched long-term sensor stability ensuring maximum yield and throughput.

Product Description

MultiFlo™ Gas and Range Configurability

A major advancement over traditional single point gas conversion factors, Brooks MultiFlo technology delivers up to a three-times improvement in process gas accuracy. This is achieved through advanced gas modeling plus extensive actual gas testing protocols that provide extremely accurate compensation. MultiFlo also allows the device to be quickly and easily configured for another gas and/or flow range without sacrificing accuracy or range-ability. Selecting a new gas automatically creates a new calibration curve, establishes optimized PID settings for dynamic control, compensates for gas density and viscosity effects, and ensures smooth, overshoot-free transitions between flow rates with excellent steady state stability.

Brooks MultiFlo technology offers unparalleled flexibility; a single device can be configured for thousands of different gas and flow range configurations.

Re-programming is simple and fast; a new gas and range can be programmed in under 30 seconds. Brooks provides an enormous gas database to ensure the maximal value of MultiFlo is realized:

- Dramatically reduces inventory or spares expense
- The MFC full scale flow range can be scaled down typically by a factor of 3:1 with no impact on accuracy, turndown or leak-by specifications for tremendous process flexibility
- Native gas calibration is not required
- Maximum flexibility for research applications

MultiFlo™ Configurator Accessories

MultiFlo kits are available in two configurations:

778Z010ZZZ Basic MultiFlo Configurator Kit
 MultiFlo configurator software
 A331710003 Cable Assembly 2.5mm
 A332300001 Converter RS-232/485

778Z011ZZZ MultiFlo Config Kit with Power Supply and Adapter Cables
 MultiFlo configurator software
 A331710003 Cable Assembly 2.5mm
 A332300001 Converter RS-232/485
 A332295001 MFC/MFM Power Supply
 A332297002 9 Pin Power Cable
 A332297001 DNet Power Cable

*MultiFlo configurator software is available on the Brooks Instrument website at: www.BrooksInstrument.com/MultiFlo

GF40/GF80 MFC

MultiFlo™ technology allows your GF40/GF80 to be programmed for thousands of different gases and flow ranges

# of Platforms	GF40/GF80 Range	Competitor A 2 Models Range	Competitor B 4 Models Range
1	3 - 10	10	1 - 5
2	11 - 30	17.5	6 - 14
3	31 - 92	30	15 - 27
4	93 - 280	55	28 - 38
5	281 - 860	100	39 - 71
6	861 - 2,600	175	72 - 103
7	2,601 - 7,200	300	104 - 192
8	7,201 - 15,000	550	193 - 279
9	15,001 - 30,000	1,000	280 - 754
10	30,001 - 50,000	1,750	755 - 2,037
11		3,000	2,038 - 5,500
12		5,500	5,501 - 11,000
13		10,000	11,001 - 30,000
14		22,000	30,001 - 50,000
15		30,000	
16		50,000	

The Brooks Advantage! Less platforms means more process flexibility and lower cost of spares.

Product Description

Enhanced Diagnostics

The mass flow controller remains one of the most complex and critical component in gas delivery systems; removing the mass flow controller to determine if it is faulty should be the last resort. In response to this fact, Brooks pioneered smarter mass flow controllers with embedded self test routines and introduced an independent diagnostic/service port to provide the user with access to diagnostic data for troubleshooting without interrupting flow controller operation.

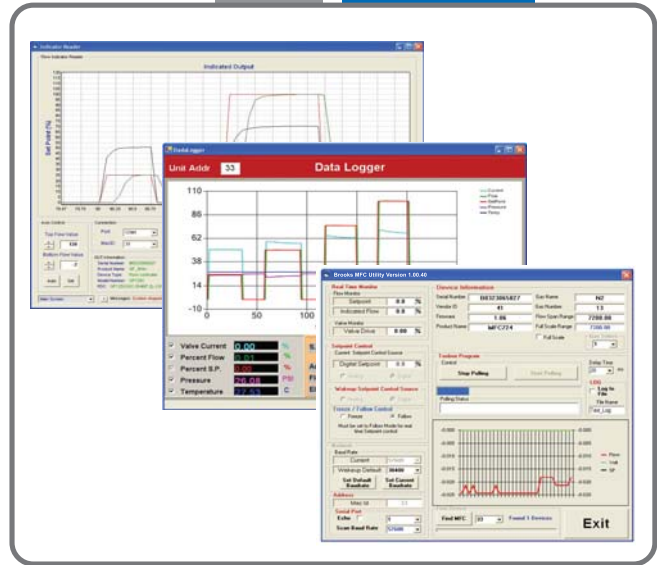

Advanced Thermal Flow Measurement Sensor

Brooks' proprietary sensor technology combines:

- Improved signal to noise performance for improved accuracy at low setpoints
- Improved reproducibility at elevated temperatures through new isothermal packaging, onboard conditioning electronics with ambient temperature sensing and compensation
- Improved long-term stability through an enhanced sensor manufacturing process
- Highly corrosion resistant Hastelloy C-22 sensor tube
- Optimized temperature profile for gases prone to thermal decomposition
- Unique orthogonal sensor mounting orientation
 - Eliminates sensor drift caused by valve heating effects
 - Eliminates thermal siphoning effects for the most common mounting orientations

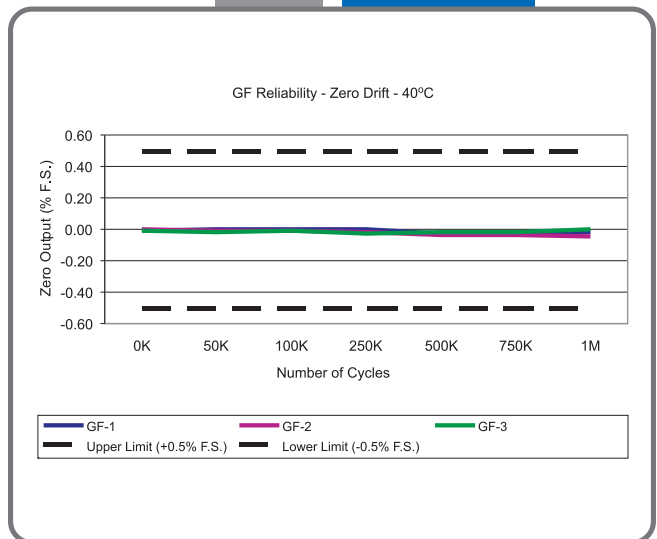

Manifold/Gas Stick Solutions

Many users are looking to reduce the foot print of the gas delivery system by employing standard or customer downport configurations. Brooks will work with you on a proprietary stick, manifold or panel design using downport components as appropriate to satisfy the requirements of the application.



Product Applications

Solar Cells / CVD

Developed to meet the diverse process requirements for solar cells, fiber optics, and glass and metals coatings markets, the GF40/GF80 mass flow controllers offer a single platform solution for diffusion furnace, thin film deposition, and other difficult applications.

With the GF40 offering elastomer seals and GF80 offering metal seals, this single platform can cover complex gas distribution systems. The MultiFlo feature can minimize costly inventory while providing industry leading actual gas accuracy.

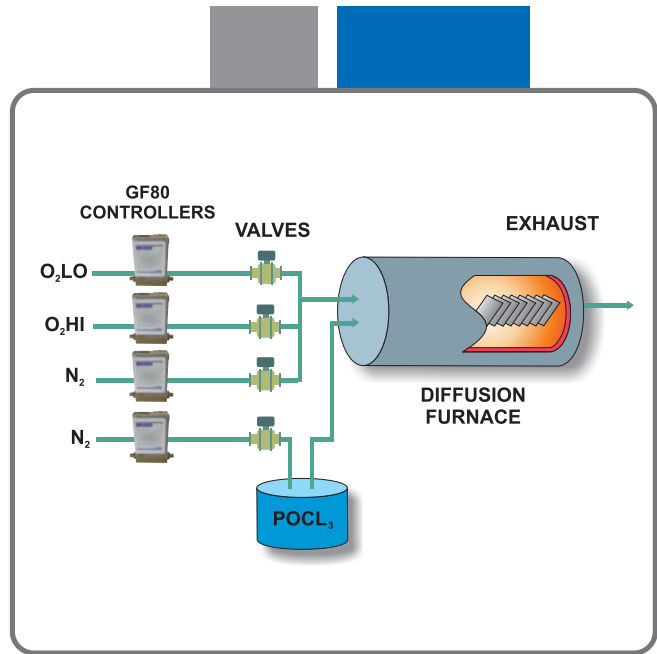
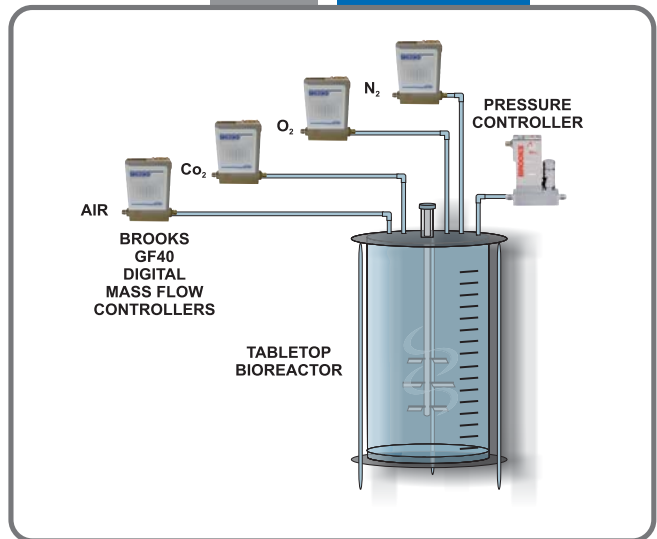

Table Top Bioreactors

Brooks has earned the leading reputation in controlling gas flows for bioreactor applications. The GF40 mass flow controllers are perfect for controlling dissolved oxygen and pH. The MultiFlo capability can greatly simplify spares inventory and the ordering process. With multiple digital protocol communication options and other advanced features, the GF40 is an ideal device for the bioreactor process.



Vacuum Processes

Brooks offers many products that deliver exceptional performance for vacuum processes. The GF40/GF80 mass flow controllers are no exception. With elastomer and metal seal options, several digital communication protocols offerings, and the MultiFlo capability, the GF40/GF80 can serve a wide variety of vacuum processes.

With Brooks other products like the XacTorr® capacitance manometer and SLA7800 Series pressure controllers, the GF40/GF80 makes Brooks a one-stop-shop for instrumentation in vacuum processes.

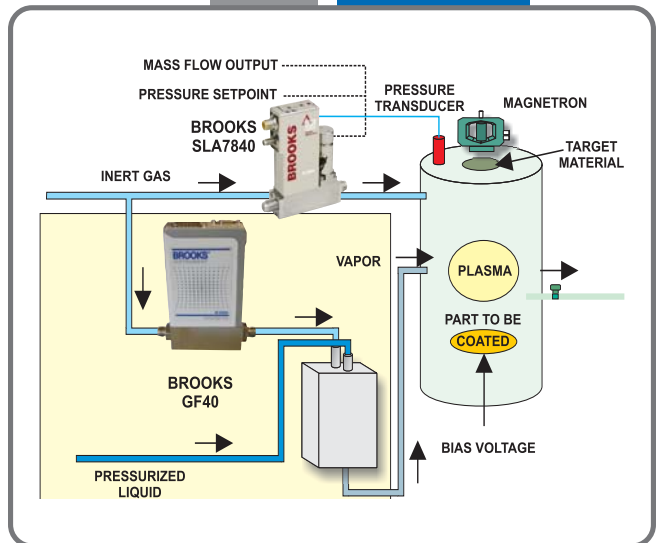

Product Specifications

Performance	GF40	GF80
Full Scale Flow Range	3 sccm to 50 slm	
Flow Accuracy	±1% S.P. 35-100%, ±0.35% F.S. 2-35%	
Repeatability & Reproducibility	< ± 0.2% S.P.	
Linearity	± 0.5% F.S. (included in accuracy)	
Response Time (Settling Time)	< 1 sec.	
Control Range	2-100% (Normally Closed Valve)	
MultiFlo	optional	
Number of Bins	10 bins	
Valve Shut Down	< 1% of F.S. (Normally Closed Valve)	
Zero Stability	< ± 0.5% F.S. per year	
Pressure Coefficient	0.007% per psi (0-50psi N2)	
Temperature Coefficient	0.05% full scale per °C	
Attitude Sensitivity	<0.25% span change @ 90° after rezeroing (N2 @ 50 psi)	
Auto Zero:	Standard option	

Ratings

Operating Temperature Range	5-50°C (41-122°F)
Maximum Operating Pressure	150 psig (10 bar)
Differential Pressure Range	3-860 sccm = 7-45 psid, 861-7200 sccm = 15-45 psid, 7201-50000 sccm = 25-45 psid Typical pressure drop, Argon gas applications require an additional 10 psid differential pressure
Leak Integrity (External)	Elastomer Seal 1x10 ⁻⁹ atm. cc/sec He, Metal Seal 1x10 ⁻¹⁰ atm. cc/se He

Mechanical

Valve Type	Normally Closed	
Valve Type	Meter Only	
Primary Wetted Materials	316 Stainless Steel, Hastelloy C-22, 17-7 PH, 430SS and Elastomer	
External Seals	Viton, Buna, Kalrez, EPDM or Neoprene	316SS
Internal Seals/Valve Seat	Viton, Buna, Kalrez, EPDM or Neoprene	PFA/Kalrez

Electrical

Diagnostic / Service Port	All variations have an RS485 Diagnostic/Service port via 2.5mm jack	
Profibus		
Electrical Connection:	1 x 15-pin Male Sub-D / 1 x 9-pin Female Sub-D	
Analog I/O:	0-5V, 0-20mA, 4-20mA	
Power:	+13.5Vdc to +27Vdc / 7 Watt max	
RS485/Analog		
Digital Communication Protocol:	5-Protocol (proprietary protocol based on HART command set)	
Electrical Connection:	1 x 15-pin Male Sub-D, (A), AUX Valve Drive (RELAY)	
Analog I/O:	0-5V, 0-10V, 0-20mA, 4-20mA	
Power:	+12Vdc to +24Vdc / normal operation 7 Watt max, Purge 9 Watt	
DeviceNet		
Electrical Connection:	1 x M12 with threaded coupling nut (B)	
Analog I/O:	0-5V	
Power:	+11Vdc to +25Vdc / 7 Watt max	

Product Specifications

Electrical (continued)

	GF40	GF80
EtherCAT		
Electrical Connection:	5 pin M8 with threaded coupling nut / 2 x RJ45	
Analog I/O:	0-5V, 0-10V	
Power:	+13.5Vdc to +27Vdc / 7 Watt max	

Diagnostics & Display

Status Lights	MFC Health, Network Status
Alarms	Sensor Output, Control Valve Output, Over Temperature, Power Surge/Sag, Network Interruption
Diagnostic / Service Port:	RS485 via 2.5mm jack

Compliance

Environmental Compliance	CE: EN61326: 2006 (FCC Part 15 & Canada IC-subset of CE testing)
	Safety EN61010-1
	RoHS

Electrical Interface Options

Base I/O Options

Analog / RS485

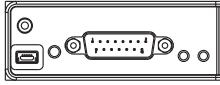

Pin No.:	Signals:
1	SETPOINT COMMON
2	FLOW OUTPUT (0-5V, 0-10V)
3	ALARM OUT
4	FLOW OUTPUT (0-20mA, 4-20mA)
5	POWER SUPPLY (+12 to +24 Vdc)
6	NC
7	SETPOINT INPUT (0-20mA, 4-20mA)
8	SETPOINT INPUT (0-5V, 0-10V)
9	POWER COMMON
10	FLOW OUT COMMON
11	NC
12	VALVE OVERRIDE INPUT
13	AUX INPUT (0-5V, 0-10V)
14	RS485B
15	RS485A

Profibus

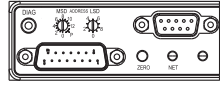

Pin No.:	Signals:
1	SETPOINT COMMON
2	FLOW OUTPUT (0-5V)
3	ALARM OUT
4	FLOW OUTPUT (0-20mA, 4-20mA)
5	POWER SUPPLY (13.5-27V)
6	NC
7	SETPOINT INPUT (0-20mA, 4-20mA)
8	SETPOINT INPUT (0-5V)
9	POWER COMMON
10	FLOW OUT COMMON
11	NC
12	VALVE OVERRIDE INPUT
13	AUX INPUT (0-5V, 0-10V) FUTURE USE
14	NC
15	NC

DeviceNet

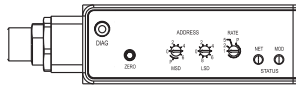

Pin No.:	Signals:
1	DRAIN
2	V+ (11-25 Vdc)
3	V-
4	CAN-H
5	CAN-L



Pin No.:	Signals:
1	FLOW OUT (0-5V)
2	AGND
3	AUX INPUT (0-5V or 0-10V)
4	EARTH GND

Pin No.:	Signals:
1	NC
2	NC
3	RXD/TXD - B - red wire
4	NC
5	Ground
6	+5Vdc
7	NC
8	RXD/TXD - A - green wire
9	NC

Product Dimensions (GF40)

GF40 Configurations

Analog / RS485

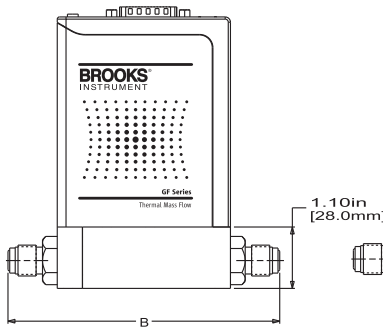

Profibus

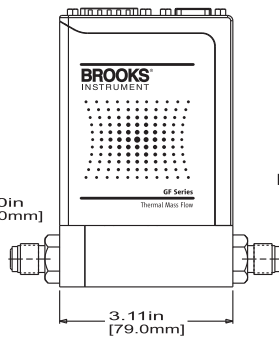

DeviceNet

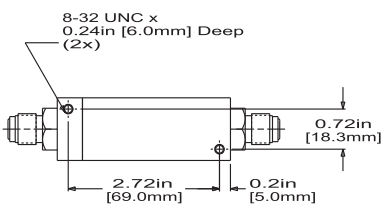
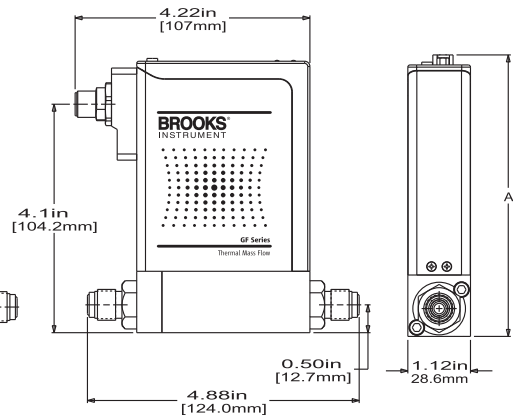

Conn. Type	Dim "B" in[mm]
9/16-18 UNF	3.11 [79]
1/4 in TC	4.94 [125.5]
1/8 in TC	4.84 [123]
1/4 in VCR	4.88 [124]
1/4 in VCO	4.61 [117]
1/4 in NPT	4.58 [116.4]
1/4 in RC	4.58 [116.4]
6mm TC	5.02 [127.6]
10mm TC	5.16 [131]

	Dim "A" in[mm]
Analog/RS485	5.06 [128.5]
Profibus	5.00 [127]
DeviceNet	4.92 [125.1]

Product Dimensions (GF80)

GF80 Downport Configurations

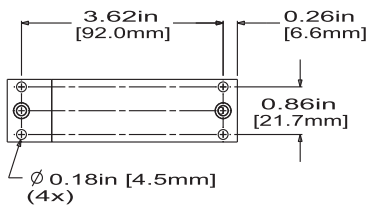
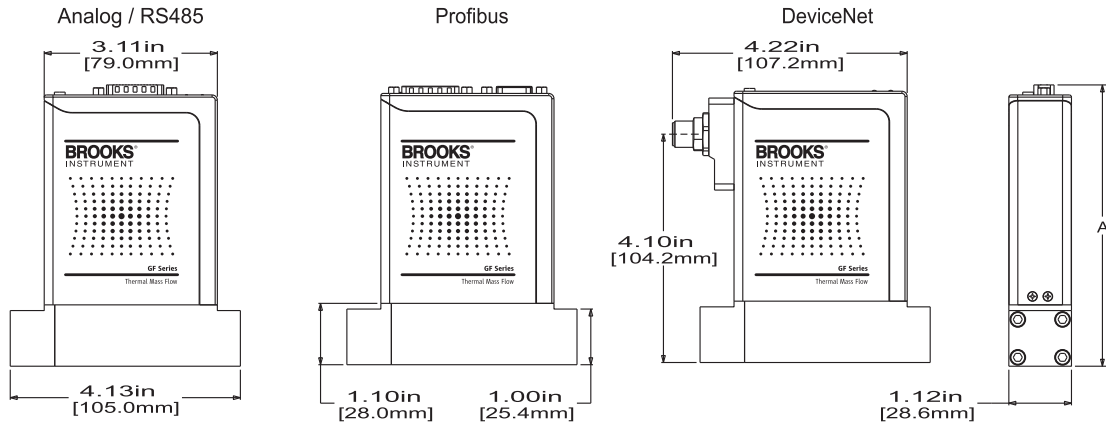

	Dim "A" in [mm]
Analog / RS485	5.06 [128.5]
Profibus	5.00 [127.1]
DeviceNet	4.92 [125.1]

GF80 VCR Configurations

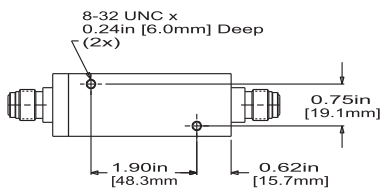
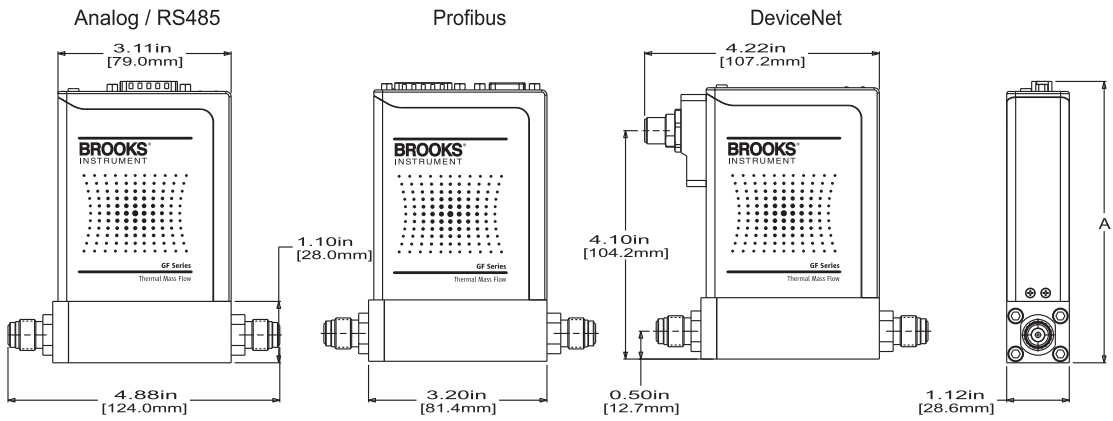

	Dim "A" in [mm]
Analog / RS485	5.06 [128.5]
Profibus	5.00 [127.0]
DeviceNet	4.92 [125.1]

Model Code

Code Description	Code Option	Option Description
I. Base Model Code	GF040	Elastomer / Range Flow (0-50 slpm)
	GF080	Metal / Range Flow (0-50 slpm)
II. Configurability	C	MultiFlo Capable. Standard Bins or specific gas range may be selected
	X	Not MultiFlo Capable. Specific gas/range required
III. Special Application	XX	Standard
IV. Valve Configuration	C	Normally Closed valve
	M	Meter (No Valve)
V. MultiFlo Bin & Range or Gas & Range (Standard)	XXXX XXXX	Specific Gas Code & Range, example: "0004" = Argon and "010L" = 10 slpm
	SA40 010C	Standard Configuration #40, 3-10 sccm N2 Eq. @ 0 deg C Ref Temp.
	SA41 030C	Standard Configuration #41, 11-30 sccm N2 Eq. @ 0 deg C Ref Temp.
	SA42 092C	Standard Configuration #42, 31-92 sccm N2 Eq. @ 0 deg C Ref Temp.
	SA43 280C	Standard Configuration #43, 93-280 sccm N2 Eq. @ 0 deg C Ref Temp.
	SA44 860C	Standard Configuration #44, 281-860 sccm N2 Eq. @ 0 deg C Ref Temp.
	SA45 2-6L	Standard Configuration #45, 861-2600 sccm N2 Eq. @ 0 deg C Ref Temp.
	SA46 7-2L	Standard Configuration #46, 2601-7200 sccm N2 Eq. @ 0 deg C Ref Temp.
	SA47 015L	Standard Configuration #47, 7201-15000 sccm N2 Eq. @ 0 deg C Ref Temp.
	SA48 030L	Standard Configuration #48, 15001-30000 sccm N2 Eq. @ 0 deg C Ref Temp.
SA50 055L	Standard Configuration #50, 30001-50000 sccm N2 Eq. @ 0 deg C Ref Temp.	
VI. Fitting	XX	9/16" - 18 UNF (GF40 Only)
	CX	1-1/8" C Seal 92mm (GF80 Only)
	T1	1/8" tube compression (GF40 Only)
	T2	1/4" tube compression (GF40 Only)
	T3	3/8" tube compression (GF40 Only)
	T4	1/2" tube compression (GF40 Only)
	T6	6mm tube compression (GF40 Only)
	T0	10mm tube compression (GF40 Only)
	R2	1/4" RC (BSP) (GF40 Only)
	VX	1/4" VCR (GF40, GF80)
	V4	3/8" - 1/2" VCR (GF40 Only)
	O2	1/4" VCO (GF40 Only)
	O4	3/8" - 1/2" VCO (GF40 Only)
	N2	1/4" NPT (GF40 Only)
VII. Downstream Condition	A	Atmosphere
	V	Vacuum
	P	Positive Pressure
VIII. External Seals, Valve Seat	B	Seal Buna / Seat Buna (GF40 Only)
	E	Seal EPDM / Seat EPDM (GF40 Only)
	K	Seal Kalrez / Seat Kalrez (GF40 Only)
	N	Seal Neoprene / Seat Neoprene (GF40 Only)
	V	Seal Viton / Seat Viton (GF40 Only)
	Z	Seal 316SS / Seat Kalrez (GF80 Only)
IX. Communications / Connector	P5	Profibus / Analog (Input 0-5V; Output 0-5V); 9-Pin Female D conn. / 15-Pin Male D conn.
	P0	Profibus / Analog (Input 0-20mA; Output 0-20mA); 9-Pin Female D conn. / 15-Pin Male D conn.
	P4	Profibus / Analog (Input 4-20mA; Output 4-20mA); 9-Pin Female D conn. / 15-Pin Male D conn.
	E5	EtherCAT™ / Analog (Output 0-5V); 2xRJ45 signal 2-Pin power / 3-Pin analog signal
	D5	DeviceNet / Analog (Output 0-5V); 5-Pin mico signal and power / 3-Pin analog signal
	S5	RS485 S-Protocol/Analog (Input 0-5V; Output 0-5V); 15-Pin Male D (Pin align. w/Brooks SLA SSII)
	S1	RS485 S-Protocol/Analog (Input 0-10V; Output 0-10V); 15-Pin Male D (Pin align. w/Brooks SLA SSII)
	S0	RS485 S-Protocol/Analog (Input 0-20mA; Output 0-20mA); 15-Pin Male D (Pin align. w/Brooks SLA SSII)
	S4	RS485 S-Protocol/Analog (Input 4-20mA; Output 4-20mA); 15-Pin Male D (Pin align. w/Brooks SLA SSII)
X. Customer Special Request	XXXX	Customer Special Request Number
XI. Auto Shut-Off	A	Auto Shut-Off (Included)
	X	Auto Shut-Off (Not Included)
XII. Auto Zero	A	Auto Zero (Included)
	X	Auto Zero (Not Included)
XIII. Reference Temperature	00C	0°C Reference
	15C	15°C Reference
	20C	20°C Reference
	70F	21.1°C Reference / 70°F Reference

Example Model Code

I	II	III	IV	V	VI	VII	VIII	IX	X	XI	XII	XIII
GF040	C	XX	C	- 0013300C -	T2	A	V	P5	- XXXX	X	A	- 20C

*THIS PAGE WAS
INTENTIONALLY
LEFT BLANK*

Brooks Service and Support

Brooks is committed to assuring all of our customers receive the ideal flow solution for their application, along with outstanding service and support to back it up. We operate first class repair facilities located around the world to provide rapid response and support. Each location utilizes primary standard calibration equipment to ensure accuracy and reliability for repairs and recalibration and is certified by our local Weights and Measures Authorities and traceable to the relevant International Standards.

Visit www.BrooksInstrument.com to locate the service location nearest to you.

START-UP SERVICE AND IN-SITU CALIBRATION

Brooks Instrument can provide start-up service prior to operation when required. For some process applications, where ISO-9001 Quality Certification is important, it is mandatory to verify and/or (re)calibrate the products periodically. In many cases this service can be provided under in-situ conditions, and the results will be traceable to the relevant international quality standards.

CUSTOMER SEMINARS AND TRAINING

Brooks Instrument can provide customer seminars and dedicated training to engineers, end users, and maintenance persons.

Please contact your nearest sales representative for more details.

HELP DESK

In case you need technical assistance:

USA	+888 275 8946	Taiwan	+886 3 5590 988
Europe	+49 351 215 2040	China	+86 21 5079 8828
Japan	+81 3 5633 7100	Singapore	+6297 9741
Korea	+82 31 708 2521		

Due to Brooks Instrument's commitment to continuous improvement of our products, all specifications are subject to change without notice.

DS-TMF-GF40-GF80-MFC-eng (1011)

TRADEMARKS

Brooks	Brooks Instrument, LLC
DeviceNet	Open DeviceNet Vendors Association, Inc.
EtherCAT	EtherCat Technology Group
Hastelloy	Haynes International
Kalrez	DuPont Performance Elastomers
MultiFlo	Brooks Instrument, LLC
Profibus	Profibus International
VCR	Cajon Co.
Viton	DuPont Performance Elastomers
XacTorr	Brooks Instrument, LLC



Brooks Instrument
 407 West Vine Street
 P.O. Box 903
 Hatfield, PA 19440-0903 USA
 T (215) 362 3700
 F (215) 362 3745
 E-Mail BrooksAm@BrooksInstrument.com
www.BrooksInstrument.com

Brooks Instrument
 Neonstraat 3
 6718 WX Ede, Netherlands
 T +31 (0) 318 549 300
 F +31 (0) 318 549 309
 E-Mail BrooksEu@BrooksInstrument.com

Brooks Instrument
 1-4-4 Kitasuna Koto-Ku
 Tokyo, 136-0073 Japan
 T +81 (0) 3 5633 7100
 F +81 (0) 3 5633 7101
 E-Mail BrooksAs@BrooksInstrument.com

