

General Specifications

EJX110A Differential Pressure Transmitter



GS 01C25B01-01E

[Style: S2]

The high performance differential pressure transmitter EJX110A features single crystal silicon resonant sensor and is suitable to measure liquid, gas, or steam flow as well as liquid level, density and pressure. EJX110A outputs a 4 to 20 mA DC signal corresponding to the measured differential pressure. Its highly accurate and stable sensor can also measure the static pressure which can be shown on the integral indicator or remotely monitored via BRAIN or HART communications. Other key features include quick response, remote set-up using communications, self-diagnostics and optional status output for pressure high/low alarm. FOUNDATION Fieldbus protocol type is also available. All EJX series models in their standard configuration, with the exception of the Fieldbus type, are certified by TÜV as complying with SIL 2 for safety requirement.



■ STANDARD SPECIFICATIONS

Refer to GS 01C25T02-01E for Fieldbus communication type marked with “◇.”

□ SPAN AND RANGE LIMITS

Measurement Span/Range	kPa	inH ₂ O/(D1)	mbar/(D3)	mmH ₂ O/(D4)	
L	Span	0.1 to 10	0.4 to 40	1 to 100	10 to 1000
	Range	-10 to 10	-40 to 40	-100 to 100	-1000 to 1000
M	Span	0.5 to 100	2 to 400	5 to 1000	50 to 10000
	Range	-100 to 100	-400 to 400	-1000 to 1000	-10000 to 10000
H	Span	2.5 to 500	10 to 2000	25 to 5000	0.025 to 5 kgf/cm ²
	Range	-500 to 500	-2000 to 2000	-5000 to 5000	-5 to 5 kgf/cm ²

T01E.EPS

□ PERFORMANCE SPECIFICATIONS

Zero-based calibrated span, linear output, wetted parts material code S and silicone oil, unless otherwise mentioned.

For Fieldbus communication type, use calibrated range instead of span in the following specifications.

Specification Conformance

EJX series ensures specification conformance to at least $\pm 3\sigma$.

Reference Accuracy of Calibrated Span

(includes terminal-based linearity, hysteresis, and repeatability)

Measurement span	H	
Reference accuracy	X \leq span	$\pm 0.04\%$ of Span
	X > span	$\pm (0.005 + 0.0049 \text{ URL}/\text{span})\%$ of Span
X	70 kPa (280 inH ₂ O)	
URL (upper range limit)	500 kPa (2000 inH ₂ O)	

T08E.EPS

Measurement span	M	
Reference accuracy	X \leq span	$\pm 0.04\%$ of Span
	X > span	$\pm (0.005 + 0.0035 \text{ URL}/\text{span})\%$ of Span
X	10 kPa (40 inH ₂ O)	
URL (upper range limit)	100 kPa (400 inH ₂ O)	

T02E.EPS

Measurement span	L	
Reference accuracy	X \leq span	$\pm 0.04\%$ of Span
	X > span	$\pm (0.015 + 0.005 \text{ URL}/\text{span})\%$ of Span
X	2 kPa (8 inH ₂ O)	
URL (upper range limit)	10 kPa (40 inH ₂ O)	

T03E.EPS

Square Root Output Accuracy

The square root accuracy is a percent of flow span.

Output	Accuracy
50% or Greater	Same as reference accuracy
50% to Dropout point	$\frac{\text{Reference accuracy} \times 50}{\text{Square root output}} (\%)$

T03E.EPS

Ambient Temperature Effects per 28°C (50°F) Change

Capsule	Effect
H	$\pm (0.04\% \text{ Span} + 0.0125\% \text{ URL})$
M	$\pm (0.04\% \text{ Span} + 0.009\% \text{ URL})$
L	$\pm (0.055\% \text{ Span} + 0.09\% \text{ URL})$

Static Pressure Effects per 6.9 MPa (1000 psi) Change

Span Effects
L, M and H capsules
 $\pm 0.075\%$ of span

Effect on Zero

Capsule	Effect
H	$\pm 0.028\% \text{ URL}$
M	$\pm 0.02\% \text{ URL}$
L	$\pm 0.05\% \text{ URL}$

Overpressure Effects

Overpressure condition: up to maximum working pressure

M and H capsules
 $\pm 0.03\%$ of URL

● **Total Probable Error (M capsule)**

±0.12% of Span @ 1:1 to 5:1 Rangedown

Total probable error, known as a measure of the total performance of the transmitters under the condition of fixed line pressure.

$$\text{Total Probable Error} = \pm \sqrt{E_1^2 + E_2^2 + E_3^2}$$

E1: Reference Accuracy of Calibrated Span
E2: Ambient Temperature Effects per 28°C change
E3: Static Span Effects per 6.9 MPa change

● **Total Accuracy (M capsule)**

±0.12% of Span @ 1:1 Rangedown

±0.25% of Span @ 5:1 Rangedown

Total accuracy is a comprehensive measure of transmitter total performance, covering all major factors in actual installation, that cause errors in measurement.

As a standard measure, YOKOGAWA uses this to evaluate transmitter performance.

$$\text{Total Accuracy} = \pm \sqrt{E_1^2 + E_2^2 + (E_3 + E_4)^2 + E_5^2}$$

E1: Reference Accuracy of Calibrated Span
E2: Ambient Temperature Effects per 28°C change
E3: Static Span Effects per 6.9 MPa change
E4: Static Zero Effects per 6.9 MPa change
E5: Overpressure Effects upto overpressure 25MPa

Not only a day-to-day changes in temperature can affect the measurement and lead to unnoticed errors; fluctuation of line pressure, incorrect operation of three/five valve manifold leading to over-pressure events, and other phenomena can have the similar result. Total Accuracy factors in such changes and errors and provides much comprehensive and practical determination of how a transmitter will perform under actual plant operation.

Stability (All normal operating condition, including overpressure effects)

M and H capsules

±0.1% of URL per 10 years

Power Supply Effects (Output signal code D and E)

±0.005 % per Volt (from 21.6 to 32 V DC, 350 Ω)

Vibration Effects

Amplifier housing code 1:

Less than 0.1% of URL when tested per the requirements of IEC60770-1 field or pipeline with high vibration level (10-60 Hz, 0.21 mm peak to peak displacement/60-2000 Hz 3 g)

Amplifier housing code 2:

Less than ±0.1% of URL when tested per the requirements of IEC60770-1 field with general application or pipeline with low vibration level (10-60 Hz 0.15mm peak to peak displacement /60-500 Hz 2g)

Mounting Position Effects

Rotation in diaphragm plane has no effect. Tilting up to 90 degree will cause zero shift up to 0.4 kPa (1.6 inH₂O) which can be corrected by the zero adjustment.

Response Time (Differential pressure) “◇”

L, M and H capsules : 90 msec

When amplifier damping is set to zero and including dead time of 45 msec (nominal)

Static Pressure Signal Range and Accuracy

(For monitoring via communication or on indicator. Includes terminal-based linearity, hysteresis, and repeatability)

Range

Upper Range Value and Lower Range Value of the static pressure can be set in the range between 0 and Maximum Working Pressure(MWP). The upper range value must be greater than the lower range value. Minimum setting span is 0.5 MPa(73 psi). Measuring either the pressure of high pressure side or low pressure side is user-selectable.

Accuracy

Absolute Pressure

1MPa or higher : ±0.2% of span

Less than 1 MPa: ±0.2%×(1 MPa/span) of span

Gauge Pressure Reference

Gauge pressure reference is 1013 hPa (1 atm)

Note : Gauge pressure variable is based on the above fixed reference and thus subject to be affected by the change of atmospheric pressure.

□ **FUNCTIONAL SPECIFICATIONS**

Output “◇”

Two wire 4 to 20 mA DC output with digital communications, linear or square root programmable. BRAIN or HART FSK protocol are superimposed on the 4 to 20 mA signal.

Output range: 3.6 mA to 21.6 mA

Output limits conforming to NAMUR NE43 can be pre-set by option code C2 or C3.

Failure Alarm (Output signal code D and E)

Analog output status at CPU failure and hardware error;

Up-scale: 110%, 21.6 mA DC or more (standard)

Down-scale: -5%, 3.2 mA DC or less

Damping Time Constant (1st order)

Amplifier damping time constant is adjustable from 0.00 to 100.00 sec by software and added to response time.

Note: For BRAIN protocol type, when amplifier software damping is set to less than 0.5 sec, communication may occasionally be unavailable during the operation, especially while output changes dynamically. The default setting of damping ensures stable communication.

Update Period “◇”

Differential pressure: 45 msec

Static pressure: 360 msec

Zero Adjustment Limits

Zero can be fully elevated or suppressed, within the lower and upper range limits of the capsule.

External Zero Adjustment

External zero is continuously adjustable with 0.01% incremental resolution of span. Re-range can be done locally using the digital indicator with range-setting switch.

Integral Indicator (LCD display, optional) “◇”

5-digit numerical display, 6-digit unit display and bar graph.

The indicator is configurable to display one or up to four of the following variables periodically.; Measured differential pressure, differential pressure in %, scaled differential pressure, measured static pressure. See also “Factory Setting.”

Burst Pressure Limits

69 MPa (10,000 psi)

Self Diagnostics

CPU failure, hardware failure, configuration error, and over-range error for differential pressure, static pressure and capsule temperature.

User-configurable process high/low alarm for differential pressure and static pressure is also available, and its status can be output when optional status output is specified.

Signal Characterizer (Output signal code D and E)

User-configurable 10-segment signal characterizer for 4 to 20 mA output.

Status Output (optional, output signal code D and E)

One transistor contact output (sink type) to output the status of user configurable high/low alarm for differential pressure/static pressure.

Contact rating : 10.5 to 30 V DC, 120 mA DC max. Refer to ‘Terminal Configuration’ and ‘Wiring Example for Analog Output and Status Output.’

SIL Certification

EJX series transmitters except Fieldbus communication type are certified by RWTÜV Systems GmbH in compliance with the following standards;

IEC 61508: 2000; Part1 to Part 7
Functional Safety of Electrical/electronic/programmable electronic related systems; SIL 2 capability for single transmitter use, SIL 3 capability for dual transmitter use.

□ NORMAL OPERATING CONDITION

(Optional features or approval codes may affect limits.)

Ambient Temperature Limits

- 40 to 85°C (-40 to 185°F)
- 30 to 80°C (-22 to 176°F) with LCD display

Process Temperature Limits

- 40 to 120°C (-40 to 248°F)

Ambient Humidity Limits

- 0 to 100% RH

Working Pressure Limits (Silicone oil)

Maximum Pressure Limits

L capsule	16 MPa (2300 psi)
M and H capsules	25 MPa (3600 psi)

Minimum Pressure Limit

See graph below

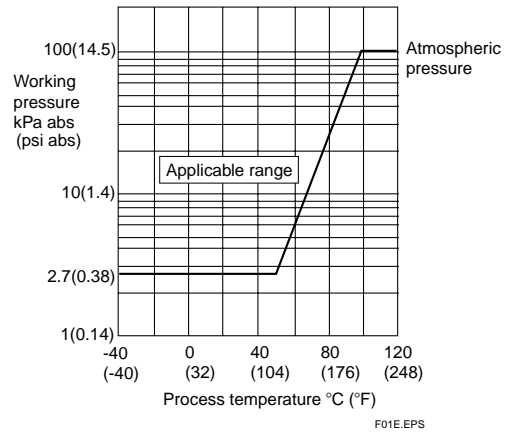

Figure 1. Working Pressure and Process Temperature

Supply & Load Requirements

(Output signal code D and E. Optional features or approval codes may affect electrical requirements.)

With 24 V DC supply, up to a 550 Ω load can be used. See graph below.

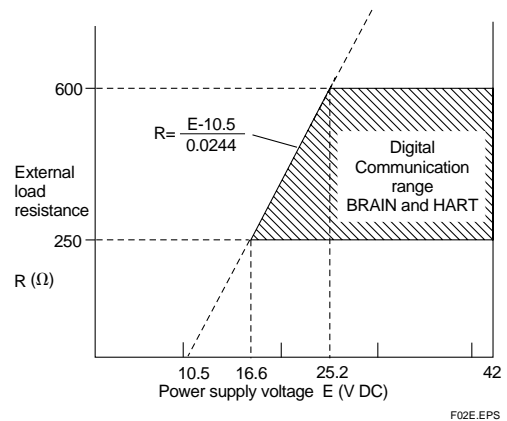

Figure 2. Relationship Between Power Supply Voltage and External Load Resistance

Supply Voltage “◇”

10.5 to 42 V DC for general use and flameproof type.
10.5 to 32 V DC for lightning protector (option code / A.)

10.5 to 30 V DC for intrinsically safe, type n, or non-incendive.

Minimum voltage limited at 16.6 V DC for digital communications, BRAIN and HART

Load (Output signal code D and E)

0 to 1290 Ω for operation
250 to 600 Ω for digital communication

Communication Requirements “◇”

(Approval codes may affect electrical requirements.)

BRAIN**Communication Distance**

Up to 2 km (1.25 miles) when using CEV polyethylene-insulated PVC-sheathed cables. Communication distance varies depending on type of cable used.

Load Capacitance

0.22 μF or less

Load Inductance

3.3 mH or less

Input Impedance of communicating device

10 kΩ or more at 2.4 kHz.

HART**Communication Distance**

Up to 1.5 km (1 mile) when using multiple twisted pair cables. Communication distance varies depending on type of cable used.

Use the following formula to determine cable length for specific applications:

$$L = \frac{65 \times 10^6}{(R \times C)} - \frac{(C_f + 10,000)}{C}$$

Where:

L = length in meters or feet

R = resistance in Ω (including barrier resistance)

C = cable capacitance in pF/m or pF/ft

C_f = maximum shunt capacitance of receiving devices in pF/m or pF/ft

EMC Conformity Standards  , 

EN 61326, AS/NZS CISPR11

European Pressure Equipment Directive 97/23/EC

Sound Engineering Practice (for all capsules)

With option code /PE3 (for M and H capsules)



Category III, Module H, Type of Equipment: Pressure Accessory-Vessel, Type of Fluid: Liquid and Gas, Group of Fluid: 1 and 2

□ PHYSICAL SPECIFICATIONS**Wetted Parts Materials****Diaphragm, Cover Flange, Process Connector, Capsule Gasket, and Vent/Drain Plug**

Refer to “MODEL AND SUFFIX CODES.”

Process Connector Gasket

PTFE Teflon

Fluorinated rubber for option code N2 and N3

Non-wetted Parts Materials**Bolting**

ASTM-B7M carbon steel, 316 SST(ISO A4-70) stainless steel, or ASTM grade 660 stainless steel

Housing

Low copper cast aluminum alloy with polyurethane, mint-green paint (Munsell 5.6BG 3.3/2.9 or its equivalent), or ASTM CF-8M Stainless Steel

Degrees of Protection

IP67, NEMA4X, JIS C0920

Cover O-rings

Buna-N

Name plate and tag

304 SST

Fill Fluid

Silicone, fluorinated oil (optional)

Weight

[Installation code 7, 8 and 9]

2.7 kg (6.0 lb) without integral indicator, mounting bracket, and process connector.

Add 1.5 kg (3.3lb) for Amplifier housing code 2.

Connections

Refer to “MODEL AND SUFFIX CODES.”

< Related Instruments >

Power Distributor: Refer to GS 01B04T01-02E or GS 01B04T02-02E

BRAIN TERMINAL: Refer to GS 01C00A11-00E

< Reference >

1. Teflon; Trademark of E.I. DuPont de Nemours & Co.
2. Hastelloy; Trademark of Haynes International Inc.
3. HART; Trademark of the HART Communication Foundation.
4. FOUNDATION Fieldbus; Trademark of Fieldbus Foundation.

Other company names and product names used in this material are registered trademarks or trademarks of their respective owners.

MODEL AND SUFFIX CODES

Model	Suffix Codes	Description
EJX110A	Differential pressure transmitter
Output signal	-D	4 to 20 mA DC with digital communication (BRAIN protocol)
	-E	4 to 20 mA DC with digital communication (HART protocol)
	-F	Digital communication (FOUNDATION Fieldbus protocol, refer to GS 01C25T02-01E)
Measurement span (capsule)	L	0.1 to 10 kPa (0.4 to 40 inH ₂ O)
	M	0.5 to 100 kPa (2 to 400 inH ₂ O)
	H	2.5 to 500 kPa (10 to 2000 inH ₂ O)
Wetted parts material *2	<input type="checkbox"/>	Refer to "Wetted Parts Material" Table below.
Process connections	0	without process connector (Rc1/4 female on the cover flanges)
	1	with Rc1/4 female process connector
	2	with Rc1/2 female process connector
	3	with 1/4 NPT female process connector
	4	with 1/2 NPT female process connector
	☆ 5	without process connector (1/4 NPT female on the cover flanges)
Bolts and nuts material	J	ASTM-B7M carbon steel
	G	316 SST (ISO A4-70) stainless steel
	C	ASTM grade 660 stainless steel
Installation	-7	Vertical piping, left side high pressure, and process connection downside
	☆ -8	Horizontal piping and right side high pressure
	-9	Horizontal piping and left side high pressure
	-B	Bottom Process Connection, left side high pressure
Amplifier housing	1	Cast aluminum alloy
	2	ASTM CF-8M Stainless Steel*3
Electrical connection	☆ 0	G1/2 female, one electrical connection without blind plugs
	☆ 2	1/2 NPT female, two electrical connections without blind plugs
	4	M20 female, two electrical connections without blind plugs
	5	G1/2 female, two electrical connections and a blind plug
	7	1/2 NPT female, two electrical connections and a blind plug
	9	M20 female, two electrical connections and a blind plug
Integral indicator	D	Digital indicator
	E	Digital indicator with the range setting switch*1
	☆ N	None
Mounting bracket	☆ B	304 SST 2-inch pipe mounting, flat type (for horizontal piping)
	D	304 SST 2-inch pipe mounting, L type (for vertical piping)
	G	304 SST 2-inch pipe mounting (for bottom process connection type)
	N	None
Optional Codes		/ <input type="checkbox"/> Optional specification

T04E.EPS

The "☆" marks indicate the most typical selection for each specification.

*1: Not applicable for output signal code **F**.

*2: ⚠ Users must consider the characteristics of selected wetted parts material and influence of process fluids. Specifying inappropriate materials has the potential to cause serious damage to human body and plant facilities resulted from an unexpected leak of the corrosive process fluids.

*3: Not applicable for electrical connection code **0**.

Table. Wetted Parts Materials

Wetted parts material code	Cover flange and process connector	Capsule	Capsule gasket	Drain/Vent plug
S #	ASTM CF-8M *1	Hastelloy C-276 *2 (Diaphragm) 316L SST (Others)	Teflon-coated 316L SST	316 SST

M04E.EPS

*1: Cast version of 316 SST. Equivalent to SCS14A.

*2: Hastelloy C-276 or ASTM N10276.

The "#marks indicate the construction materials conform to NACE material recommendations per MR01-75. For the use of 316 SST material, there may be certain limitations for pressure and temperature. Please refer to NACE standards for details.

OPTIONAL SPECIFICATIONS (For Explosion Protected type) “◇”

Item	Description	Code
Factory Mutual (FM)	FM Explosionproof Approval *1 Applicable Standard: FM3600, FM3615, FM3810, ANSI/NEMA 250 Explosionproof for Class I, Division 1, Groups B, C and D, Dust-ignitionproof for Class II/III, Division 1, Groups E, F and G, in Hazardous locations, indoors and outdoors (NEMA 4X) Temperature class: T6, Amb. Temp.: -40 to 60°C (-40 to 140°F)	FF1
	FM Intrinsically safe Approval *1*2 Applicable Standard: FM3600, FM3610, FM3611, FM3810 Intrinsically Safe for Class I, Division 1, Groups A, B, C & D, Class II, Division 1, Groups E, F & G and Class III, Division 1, Class I, Zone 0, in Hazardous Locations, AEx ia IIC Nonincendive for Class I, Division 2, Groups A, B, C & D, Class II, Division. 2, Groups F & G, and Class III, Division 1, Class I, Zone 2, Group IIC, in Hazardous Locations Enclosure: "NEMA 4X", Temp. Class: T4, Amb. Temp.: -60 to 60°C (-75 to 140°F) Intrinsically Safe Apparatus Parameters [Groups A, B, C, D, E, F and G] Vmax=30 V, Imax=200 mA, Pmax=1 W, Ci=6 nF, Li=0 μH [Groups C, D, E, F and G] Vmax=30 V, Imax=225 mA, Pmax=1 W, Ci=6 nF, Li=0 μH	FS1
	Combined FF1 and FS1 *1*2	FU1
CENELEC ATEX	CENELEC ATEX (KEMA) Flameproof Approval *1 Applicable Standard: EN 50014, EN 50018, EN 50281-1-1 Certificate: KEMA 03ATEX2570 II 2G, 1D EExd IIC T4, T5, T6 Type of protection : IP66 and IP67 Amb. Temp. (Tamb) for gas-proof : T4 ; -50 to 75°C (-58 to 167°F), T5; -50 to 80°C (-58 to 176°F), T6; -50 to 70°C (-58 to 158°F) Max. process Temp.(Tp): T4; 120°C (248°F), T5; 100°C (212°F), T6; 85°C (185°F) Max. surface Temp. for dust-proof : T80°C (Tamb: -40 to 40°C, Tp:80°C), T100°C (Tamb: -40 to 60°C, Tp:100°C), T120°C (Tamb: -40 to 80°C, Tp:120°C)	KF2
	CENELEC ATEX (KEMA) Intrinsically safe Approval *1*2 Applicable Standard: EN 50014, EN 50020, EN 50284, EN 50281-1-1 Certificate: KEMA 03ATEX1544X II 1G, 1D EEx ia IIC T4 Type of protection : IP66 and IP67 Amb. Temp.(Tamb) for gas-proof: -50 to 60°C (-58 to 140°F) Maximum Process Temp.(Tp) for gas-proof :120°C Electrical data : Ui=30 V, li=200 mA, Pi=0.9 W, Ci=10 nF, Li=0 mH Max. surface Temp. for dust-proof : T85°C (Tamb: -40 to 60°C, Tp:80°C), T100°C (Tamb: -40 to 60°C, Tp:100°C), T120°C (Tamb: -40 to 60°C, Tp:120°C)	KS2
	Combined KF2, KS2 and Type n *1*2 Type n Applicable Standard: EN 50021, EN 60529 II 3G EEx nL IIC T4, Amb. Temp.: -50 to 60°C (-50 to 140°F) Ui=30 V DC, Ci=10 nF, Li=0 mH	KU2

T05E.EPS

*1: Applicable for Electrical connection code **2, 4, 7, and 9.**

*2: Applicable for Electrical connection code **2, and 7.**

Item	Description	Code
Canadian Standards Association (CSA)	CSA Explosionproof Approval *2 Certificate: 1589701 [For CSA C22.2] Applicable Standard: C22.2 No.0, C22.2 No.0.4, C22.2 No.0.5, C22.2 No.25, C22.2 No.30, C22.2 No.94 Explosion-proof for Class I, Groups B, C and D. Dustignition-proof for Class II/III, Groups E, F and G. When installed in Division 2, "SEAL NOT REQUIRED" Enclosure: TYPE 4X, Temp. Code: T6...T4 [For CSA E60079] Applicable Standard: CAN/CSA E60079-0, CAN/CSA E60079-1 Flameproof for Zone 1, Ex d IIC T6...T4 Enclosure: IP66 and IP67 Max.Process Temp.: T4;120°C(248°F), T5;100°C(212 °F), T6; 85°C(185°F) Amb.Temp.: -50 to 75°C(-58 to 167°F) for T4, -50 to 80°C(-58 to 176°F) for T5, -50 to 70°C(-58 to 158°F) for T6	CF1
	CSA Intrinsically safe Approval *2*3 Certificate: 1606623 [For CSA C22.2] Applicable Standard: C22.2 No.0, C22.2 No.0.4, C22.2 No.25, C22.2 No.94, C22.2 No.154, C22.2 No.213, C22.2 No.1010.1 Intrinsically Safe for Class I, Division 1, Groups A, B, C & D, Class II, Division 1, Groups E, F & G, Class III, Division 1, Nonincendive for Class I, Division 2, Groups A, B, C & D, Class II, Division 2, Groups E, F & G, Class III, Division 1 Enclosure: Type 4X, Temp. Code: T4 Amb. Temp.: -50 to 60°C(-58 to 140°F) Electrical Parameters: [Intrinsically Safe] Vmax=30V, Imax=200mA, Pmax=0.9W, Ci=10nF, Li=0 [Nonincendive] Vmax=30V, Ci=10nF, Li=0 [For CSA E60079] Applicable Standard: CAN/CSA E60079-0, CAN/CSA E60079-11, CAN/CSA E60079-15, IEC 60529:2001-02 Ex ia IIC T4, Ex nL IIC T4 Enclosure: IP66 and IP67 Amb. Temp.: -50 to 60°C(-58 to 140°F), Max. Process Temp.: 120°C(248°F) Electrical Parameters: [Ex ia] Ui=30V, Ii=200mA, Pi=0.9W, Ci=10nF, Li=0 [Ex nL] Ui=30V, Ci=10nF, Li=0	CS1
	Combined CF1 and CS1 *2*3	CU1
IECEX Scheme *4	IECEx Intrinsically safe, type n and Flameproof Approval *1*3 Intrinsically safe and type n Applicable Standard: IEC 60079-0:2000, IEC 60079-11:1999, IEC 60079-15:2001 Certificate: IECEx CSA 05.0005 Ex ia IIC T4, Ex nL IIC T4 Enclosure: IP66 and IP67 Amb. Temp.: -50 to 60°C(-58 to 140°F), Max. Process Temp.: 120°C(248°F) Electrical Parameters: [Ex ia] Ui=30V, Ii=200mA, Pi=0.9W, Ci=10nF, Li=0 [Ex nL] Ui=30V, Ci=10nF, Li=0 Flameproof Applicable Standard: IEC 60079-0:2000, IEC60079-1:2001 Certificate: IECEx CSA 05.0002 Flameproof for Zone 1, Ex d IIC T6...T4 Enclosure: IP66 and IP67 Max.Process Temp.: T4;120°C(248°F), T5;100°C(212°F), T6; 85°C(185°F) Amb.Temp.: -50 to 75°C(-58 to 167°F) for T4, -50 to 80°C(-58 to 176°F) for T5, -50 to 70°C(-58 to 158°F) for T6	SU2

T05Eb.EPS

- *1: Applicable for Electrical connection code **2, 4, 7, and 9.**
- *2: Applicable for Electrical connection code **2, and 7.**
- *3: Not applicable for option code **/AL.**
- *4: Applicable only for Australia and New Zealand area.

OPTIONAL SPECIFICATIONS

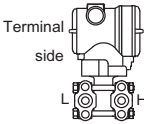
Item	Description		Code
Painting	Color change	Amplifier cover only*9	P □
		Amplifier cover and terminal cover, Munsell 7.5 R4/14	PR
	Coating change	Anti-corrosion coating*1*9	X2
Lightning protector	Transmitter power supply voltage: 10.5 to 32 V DC (10.5 to 30 V DC for intrinsically safe type.) Allowable current: Max. 6000 A (1×40 μs), Repeating 1000 A (1×40 μs) 100 times Applicable Standards: IEC 61000-4-4, IEC 61000-4-5		A
Status output*2	Transistor output (sink type) Contact rating : 10.5 to 30 V DC, 120 mA DC(max) Low level : 0 to 2 V DC		AL
Oil-prohibited use*3	Degrease cleansing treatment		K1
	Degrease cleansing treatment and with fluorinated oilfilled capsule. Operating temperature -20 to 80°C(-4 to 176°F)		K2
Oil-prohibited use with dehydrating treatment*3	Degrease cleansing treatment and dehydrating treatment		K5
	Degrease cleansing treatment and dehydrating treatment with fluorinated oilfilled capsule. Operating temperature -20 to 80°C(-4 to 176°F)		K6
Capsule fill fluid	Fluorinated oil filled in capsule		K3
Calibration units*4	P calibration (psi unit)	(See Table for Span and Range Limits.)	D1
	bar calibration (bar unit)		D3
	M calibration (kgf/cm ² unit)		D4
Long vent*5	Total length: 119 mm (standard: 34 mm); Total length when combining with option code K1, K2, K5, and K6: 130 mm. Material: 316 SST		U1
Output limits and failure operation*6	Failure alarm down-scale : Output status at CPU failure and hardware error is -5%, 3.2mA DC or less.		C1
	NAMUR NE43 Compliant Output signal limits : 3.8 mA to 20.5 mA	Failure alarm down-scale : Output status at CPU failure and hardware error is -5%, 3.2 mA DC or less.	C2
		Failure alarm up-scale : Output status at CPU failure and hardware error is 110%, 21.6 mA or more.	C3
Body option*7		Right side high pressure, without drain and vent plugs	N1
		N1 and Process connection, based on IEC61518 with female thread on both sides of cover flange, with blind kidney flanges on back.	N2
		N2, and Material certificate for cover flange, diaphragm, capsule body, and blind kidney flange	N3
Stainless steel tag plate	304SST tag plate wired onto transmitter		N4
Data configuration at factory*8	Data configuration for HART communication type	Software damping, Descriptor, Message	CA
	Data configuration for BRAIN communication type	Software damping	CB
European Pressure Equipment Directive*10	PED 97/23/EC Category III, Module H, Type of Equipment: Pressure Accessory-Vessel, Type of Fluid: Liquid and Gas, Group of Fluid: 1 and 2		PE3

T06E.EPS

- *1: Not applicable with color change option.
- *2: Check terminals cannot be used when this option code is specified. Not applicable for output signal code **F** and amplifier housing code **2**.
- *3: Applicable for Wetted parts material code **S**.
- *4: The unit of MWP (Max. working pressure) on the name plate of a housing is the same unit as specified by option codes **D1**, **D3**, and **D4**.
- *5: Applicable for vertical impulse piping type (Installation code **7**) and Wetted parts material code **S**, **H**, **M** and **T**.
- *6: Applicable for output signal codes **D** and **E**. The hardware error indicates faulty amplifier or capsule.
- *7: Applicable for wetted parts material code **S**; process connection codes **3**, **4**, and **5**; installation code **9**; and mounting bracket code **N**. Process connection faces on the other side of zero adjustment screw.
- *8: Also see 'Ordering Information'.
- *9: Not applicable for amplifier housing code **2**.
- *10: Applicable for measurement span code **M** and **H**. If compliance with category III is needed, specify this option code.

Item	Description		Code
Material certificate*1	Cover flange *2		M01
	Cover flange, Process connector *3		M11
Pressure test/ Leak test certificate*7	Test Pressure: 16 MPa(2300 psi)*4	Nitrogen(N ₂) Gas*6	T12
	Test Pressure: 25 MPa(3600 psi)*5		Retention time: one minute

T06Eb.EPS

- *1: Material traceability certification, per EN 10204 3.1B.
- *2: Applicable for process connections codes **0** and **5**.
- *3: Applicable for process connections codes **1**, **2**, **3**, and **4**.
- *4: Applicable for capsule code **L**.
- *5: Applicable for capsule codes **M** and **H**.
- *6: Pure nitrogen gas is used for oil-prohibited use (option codes **K1**, **K2**, **K5**, and **K6**).
- *7: The unit on the certificate is always Pa unit regardless of selection of option code **D1**, **D3** or **D4**.

DIMENSIONS

● Model EJX110A

Vertical Impulse Piping Type

Process connector upside (INSTALLATION CODE '7')

Unit : mm (approx.inch)

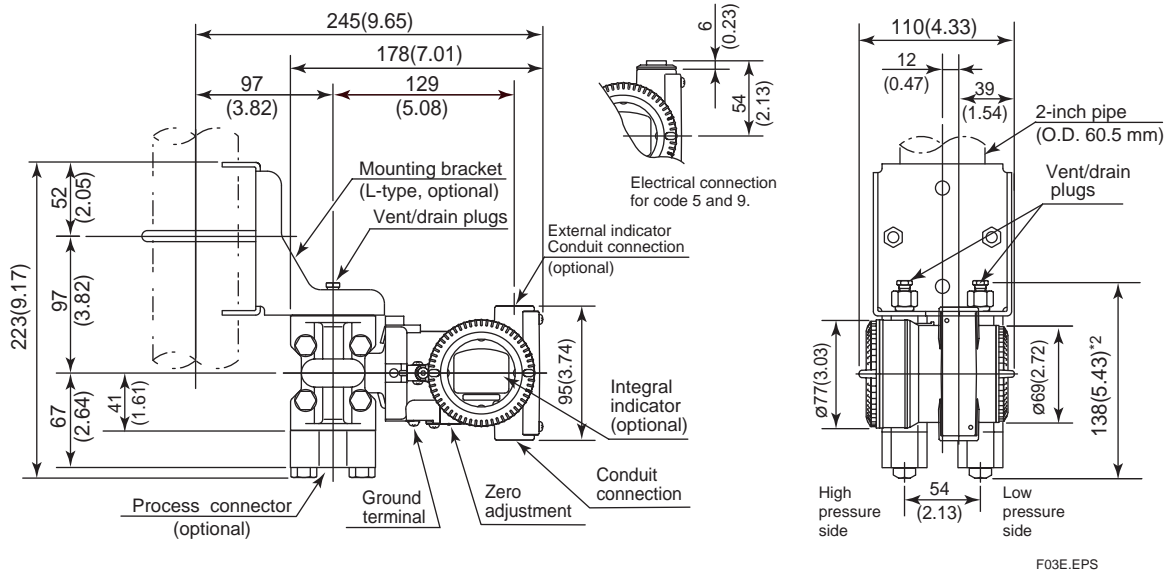

F03E.EPS

Horizontal Impulse Piping Type (INSTALLATION CODE '9') (For CODE '8', refer to the notes below.)

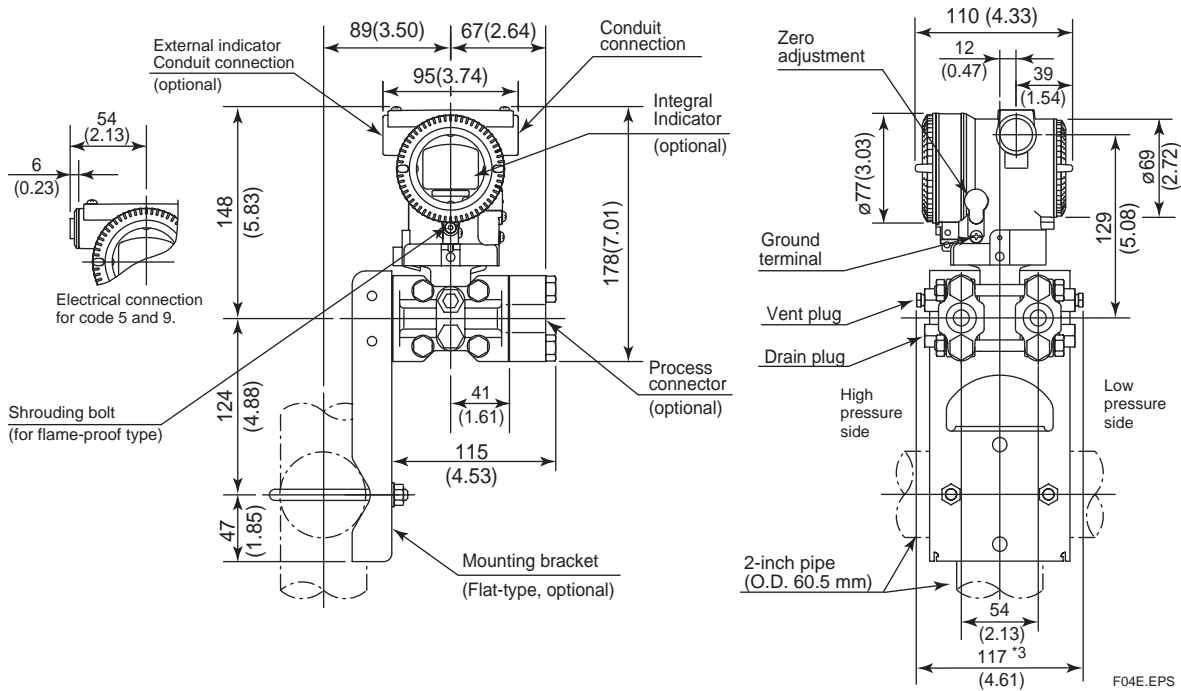

F04E.EPS

- * 1: When installation code 8 is selected, high and low pressure side on above figure are reversed. (i.e. High pressure side is on the right side.)
- * 2: When option code K1, K2, K5 or K6 is selected, add 15mm(0.59 inch) to the value in the figure.
- * 3: When option code K1, K2, K5 or K6 is selected, add 30mm(1.18 inch) to the value in the figure.

Bottom Process Connection Type (INSTALLATION CODE 'B')

Unit : mm (approx.inch)

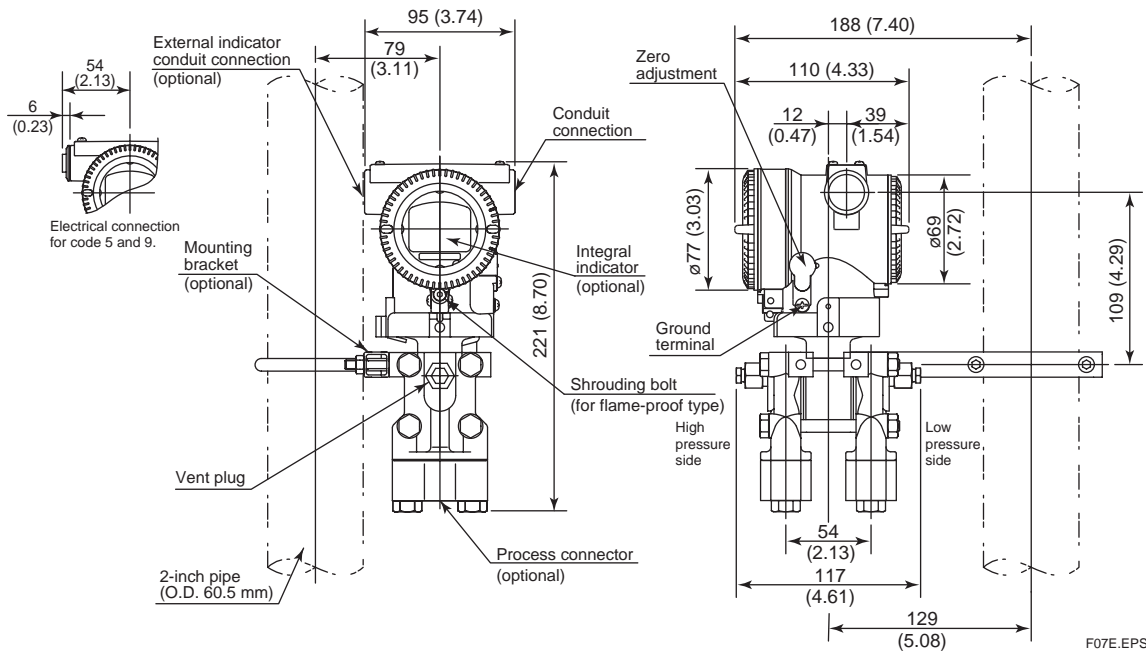

F07E.EPS

● Terminal Configuration

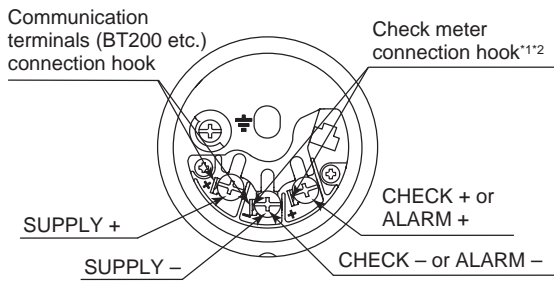

● Terminal Wiring

SUPPLY +	-	Power supply and output terminal
CHECK +	-	External indicator (ammeter) terminal ^{1,2} or Status contact output terminal ² (when /AL is specified)
ALARM +	-	
	⏏	Ground terminal

*1: When using an external indicator or check meter, the internal resistance must be 10 Ω or less. A check meter or indicator cannot be connected when /AL option is specified.

*2: Not available for fieldbus communication type.

F05E.EPS

● Wiring Example for Analog Output and Status Output

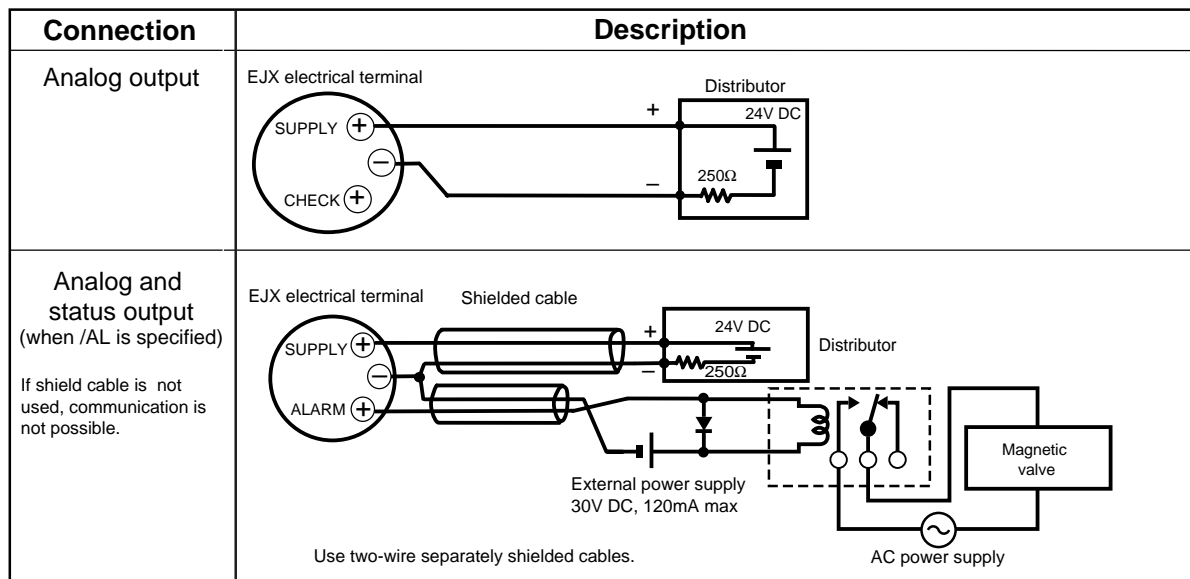

F06E.EPS

< Ordering Information > “◇”

Specify the following when ordering

1. Model, suffix codes, and option codes
2. Calibration range and units
 - 1) Calibration range can be specified with range value specifications up to 5 digits (excluding any decimal point) for low or high range limits within the range of -32000 to 32000. When reverse range is designated, specify Lower Range Value(LRV) as greater than Upper Range Value(URV).
 - 2) Specify only one unit from the table, 'Factory setting.'
3. Select linear or square root for output mode and display mode.

Note: If not specified, the instrument is shipped set for linear mode.
4. Display scale and units (for transmitters equipped with the integral indicator only)

Specify either 0 to 100 % or 'Range and Unit' for engineering units scale:
 Scale range can be specified with range limit specifications up to 5 digits (excluding any decimal point) for low or high range limits within the range of -32000 to 32000. Unit display consists of 6-digit, therefore, if the specified scaling unit excluding '/' is longer than 6-characters, the first 6 characters will be displayed on the unit display.
5. Tag Number (if required)

For BRAIN communication type, specify upto 16 letters. The specified letters will be written in the amplifier memory and engraved on the tag plate.
 For HART communication type, specify software tag (up to 8 letters) to be written on the amplifier memory and Tag number(up to 16 letters) to be engraved on the tag plate seperately.
6. Other factory configurations (if required)

Specifying option code **CA** or **CB** will allow further configuration at factory. Following are configurable items and setting range.

[/CA : For HART communication type]

 - 1) Descriptor(up to 16 characters)
 - 2) Message (up to 30 characters)
 - 3) Software damping in second (0.00 to 100.00)

[/CB : For BRAIN communication type]

 - 1) Software damping in second (0.00 to 100.00)

< Factory Setting > “◇”

Tag number	As specified in order
Software damping *1	'2.00 sec' or as specified in order
Output mode	'Linear' unless otherwise specified in order
Calibration range lower range value	As specified in order
Calibration range upper range value	As specified in order
Calibration range unit	Selected from mmH ₂ O, mmH ₂ O(68°F), mmAq ^{*2} , mmWG ^{*2} , mmHg, Pa, hPa ^{*2} , kPa, MPa, mbar, bar, gf/cm ² , kgf/cm ² , inH ₂ O, inH ₂ O(68°F), inHg, ftH ₂ O, ftH ₂ O(68°F) or psi. (Only one unit can be specified.)
Display setting	Designated differential pressure value specified in order. (% or user scaled value.) Display mode 'Linear' or 'Square root' is also as specified in order.
Static pressure display range	'0 to 25 MPa' for M and H capsule and '0 to 16 MPa' for L capsule, absolute value. Measuring high pressure side.

T07E.EPS

*1: To specify these items at factory, option code **CA** or **CB** is required.

*2: Not available for HART protocol type.