

GS 5D1A01-01E

### General

The US1000 Digital Indicating Controller has clear bar displays for PV, SV, and MV, and a wealth of control and computation functions. All kinds of operations and setting changes can be easily carried out using the front panel keys. Communication functions such as MODBUS protocol support, are provided in order to communicate with the other product models.



### Features

- 30-segment LED PV bar graph
- Comes standard with a universal input that can directly accept sensor input
- Powerful dual-loop control function
- Custom computation function that covers a wide range of applications and is created by users combining controls and computations. (This is easily created using the LL1200 PC-Based Custom Computation Building Tool.)
- Half the size of earlier instruments—being only 150 mm long.

### Functional Specifications

#### Control Functions

- Single-loop PID Control: Basic control function.  
Single-loop control, cascade primary- and secondary-loop control, loop control for backup, loop control with PV switching or PV auto-selector, loop control with PV-hold function, loop control with PV switching or PV auto-selector and two universal inputs

- Cascade Control: Performs cascade control using a single controller with two control functions, cascade control and cascade control with two universal inputs.
- Dual-loop PID Control: Both loops have their own control function and controls—dual-loop control and temperature and humidity control.
- Custom Computation Control: This control function is created by combining the computation and signal computation functions desired by the user(s). This function is created using the optional LL1200 PC-Based Custom Computation Building Tool.

### Model and Suffix Codes, Option Codes

#### Model and Number of Input/Output Points

Model	Suffix Codes	Option Codes	Description	Analog input		Analog output				Contact	
				Universal	Voltage	LPS <sup>*1</sup>	Current	Voltage	Relay	Input	Output
US1000	-00		Basic type	1	1	1	1	1	0	2	3
	-11		Enhanced type (with custom computation)	2	1	2	2	1	2	7	7
	-21		Position proportional type (with custom computation)	2	1	2	1	1	2 <sup>*2</sup>	7	7
		/A10	RS-485 communication								

\*1 : Loop power supply for transmitter

\*2 : The two contact points in the US1000-21 relay item are the relay output and the feedback resistance input.

• **Model and Control Functions**

Control function	US1000	-00	-11	-21
Single-loop control		Yes	Yes	Yes
Cascade primary-loop control		*Yes	Yes	No
Cascade secondary-loop control		*Yes	Yes	Yes
Cascade control		*Yes	Yes	Yes
Loop control for backup		*Yes	Yes	Yes
Loop control with PV switching		*Yes	Yes	Yes
Loop control with PV auto-selector		*Yes	Yes	Yes
Loop control with PV-hold function		*Yes	Yes	Yes
Dual-loop control		No	Yes	No
Temperature and humidity control		No	Yes	No
Cascade control with two universal inputs		No	Yes	Yes
Loop control with PV switching and two universal inputs		No	Yes	Yes
Loop control with PV auto-selector and two universal inputs		No	Yes	Yes
Custom computation control		No	Yes	Yes

\*The analog input-2 function is unavailable.

● **Computational Functions**

Time proportional PID, continuous PID, ON/OFF control, heating/cooling, and position proportional PID computations are provided. The computational functions set determine the output signal. "Position proportional PID computation" is only available on the US1000-21 model.

● **PID Control Functions**

Batch control and fixed setpoint control are provided.

- Basic PID: Proportional band (0.1 to 999.9%)
- \* Cooling-side proportional band (0.0 to 999.9%)
- Integral time (1 to 6000 seconds)
- Derivative time (1 to 6000 seconds)

When using the heating/cooling computation, PID settings must be made for both the heating and cooling sides.

- Preset PID function: Selects a groups of PID parameters as SVs. Up to 8 PID parameter groups are available.
- Zone PID function: Switches between PID parameter groups in accordance with input changes.  
Zone PID reference point:  
0 to 100% of measurement range  
Zone PID hysteresis: 0 to 10% of measurement range  
Zone PID reference deviation: 0 to 100% of measurement range span

● **Signal Computation Function**

Input signal computation

- Bias: -100 to 100% of measurement range span
- Filter: 1 to 120 seconds
- PV tracking: Target setpoint tracks PV intermittently, and gradually changes it back to its original value at the setpoint velocity rate
- Square root extraction
- Low signal cut-off of square root extraction: 0.0 to 5.0%

- Ten-segment linearizer: Divides the input/output into a maximum of 10 segments.

Input unit: Percentages (%), absolute values, and engineering units

Output unit: Percentages (%), absolute values, and engineering units

Input: 0 to 100%

Output: 0 to 100%

Mode: Biasing and approximation

- First order lag computation: 1 to 120 seconds

- Cascade computation

Cascade input filter: 1 to 120 seconds

Computational expression: Cascade setpoint × CRT + CBS = computation output

CRT: Cascade ratio (0.001 to 9.999)

CBS: Cascade bias

(-100 to 100% of measurement range span)

- Feedforward input:

One of the first-order lag computations

Computational expression: (Feedforward input + FBI) × FGN + FBO = computation output

FGN: Feedforward gain (-9.999 to 9.999)

FBI: Feedforward input bias (-100.0 to 100.0%)

FBO: Feedforward output bias (-999.9 to 999.9)

Feedforward input filter: 1 to 120 seconds

Output signal computation

- Output limiter: Output limiting function

Upper limit of output: -5 to 105%

Lower limit of output: -5 to 105%

- Output velocity limiter: 0.1 to 100.0%

- Output tracking:

Outputs the tracking input when the tracking flag is ON.

Effective when the controller mode is set in cascade primary-loop control or loop control for backup.

● **Control Period**

Period of control function operation is 50, 100, 200, or 500 ms (factory set default: 200 ms).

It is limited by model and suffix codes, control functions, and computational functions.

● **Other Functions**

- Auto-tuning: Changes MV several times in step-like manner and calculates suitable PID parameter values from the response data. Auto-tuning is not available with the ON/OFF control computation and can only be executed when the controller is in operation, set up for PID control, and in AUTO mode.

- SUPER function: An overshoot suppressing function based on the fuzzy logic. This function is effective in PID mode except when the integral time is OFF.

● **Custom Computation Function**

Valid when the controller mode is set at 21. This function is created using the optional LL1200 PC-Based Custom Computation Building Tool.

- Computation modules  
Addition, subtraction, multiplication, division, absolute value, reciprocal, auto-selector (min./max./average/difference), hold maximum/minimum value, hold, switch, limiter, constant, AND/OR, exclusive OR, NOT, latch, greater/lesser, decremental counter, counter, equal to, not equal to, range, delay, AND/OR (long word), word shift, sum, timer, rate-of-change limiter, 10 segment linearizer 1 and 2, inverse 10 segment linearizer 1 and 2, curve linearizer 1 and 2, ratio, First-order-lag filter, EU range conversion, switching between two inputs, temperature and humidity calculation, square-root extraction, detection of change, loop 1 and loop 2 output selection, display data unit conversion, parameter setting, data display 1 and 2, output 1 and output 2 terminal configuration, fluid temperature/pressure compensation, 10 segment linearizer 3 and 4, dead time, moving average, multi-selector, edge counter, edge timer, detection of edge change, square-root extraction 2, and flow sum.
- Number of usable computation modules: 30 modules for input and 30 for output

● Contact Input/Output Function

- Contact input function  
Operation mode (CAS, AUTO, MAN) switching can be assigned in cascade control, open/close switchover, run/stop switchover, SV selection, feedforward input switchover, loop tracking flag switchover, display interruption switchover, message display, etc.
- Contact output function  
Internal registers and relays can be assigned.

■ Display and Operation

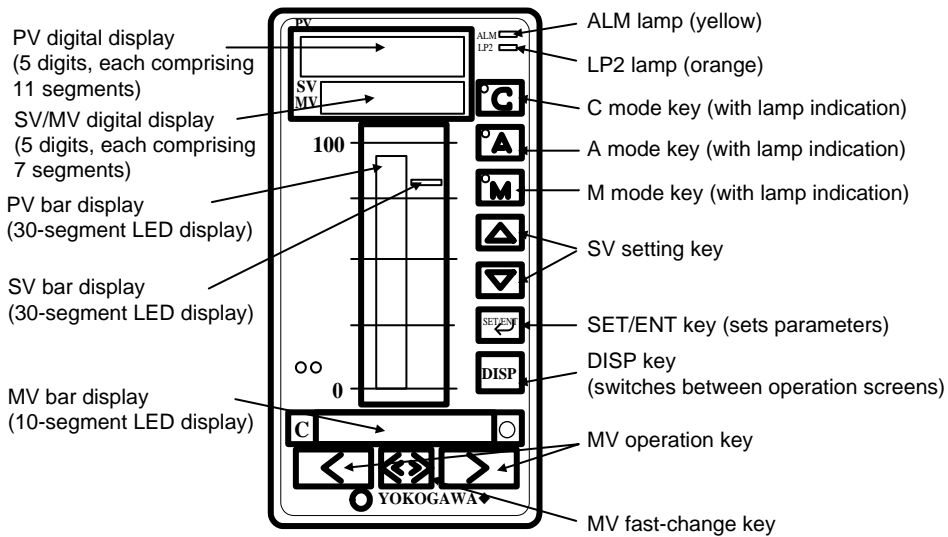

● Alarm Function

Number of alarms: 8 points (4 points for each loop) ; 7 points can be used as output contacts. All of the 8 alarm points can be read via communication.

- Alarm types  
PV high/low limit, SV high/low limit, MV high/low limit, deviation high/low limit, deviation within high and low limits, PV velocity, self-diagnosis, and fail alarms.  
The active, passive and alarm suppression state can be specified at the start of operation for all of these alarms.
- Alarm setting: Can select wither a 4 or 8 alarm mode  
4 alarm mode: 4 alarms for loop 1 only  
8 alarm mode: 4 alarms each for loop 1 and loop 2
- PV/SV alarms: -100 to 100% of measurement range
- Deviation alarms:  
-100 to 100% of measurement range span
- Timer alarms: 0.00 to 99.59 (Unit: 1 hour or 1 minute)
- Alarm hysteresis: 0 to 100% of measurement range span
- PV velocity alarm duration time: 1 to 9999 seconds
- Alarm mode: 6 types  
Sets the effective status of alarms. The 8 alarm mode cannot be selected in cascade control.

● Security Functions

These functions are used to prohibit setting changes, key operations, and menu display.

- Password function:  
Prohibits changes to parameter settings
- Key-lock function: Prohibits specific key operations
- Display lock function:  
Prohibits the display of specific menus

● Display

- Digital displays
  - PV: 5 digit, 11 segment display
  - SV/MV: 5 digit, 7 segment display
  - Data display range: -19999 to 30000
- Bar graph display
  - PV/SV: 30 segment bar display
  - 2 segment display for outside range
  - Resolution: 3.3%
  - MV: 10-segment bar display
  - 2 segment display for outside range
  - Resolution: 10%
- Indicator lamps
  - Alarm indicator, loop 2 status indicator, operation mode (CAS, AUTO, MAN) indicator, and MV indicator lamps

● Operation

- Operation keys: (CAS, AUTO, MAN) mode keys
  - (Δ, ▽) SV setting keys
  - (<, >) MV operation keys
  - (<< >>) MV fast key
  - (DISP) DISP key
  - (SET/ENT) SET/ENT key

● Input table

Input type		Setting	Instrument Range (°C)	Instrument Range (°F)	Accuracy for % of instrument range
Thermocouple	K	1	-270.0 to 1370.0°C	-450.0 to 2500.0°F	0°C and over: ±0.1% of F.S. Below 0°C : ±0.2% of F.S. K (below -200°C) : ±2% of F.S.
		2	-270.0 to 1000.0°C	-450.0 to 2300.0°F	
		3	-200.0 to 500.0°C	-200.0 to 1000.0°F	
	J	4	-200.0 to 1200.0°C	-300.0 to 2300.0°F	T (below -200°C) : ±1% of F.S.
		T	5	-270.0 to 400.0°C	
	B		6	0.0 to 400.0°C	-200.0 to 750.0°F
		7	0.0 to 1800.0°C	32 to 3300°F	
	S	8	0.0 to 1700.0°C	32 to 3100°F	±0.15% of F.S.
	R	9	0.0 to 1700.0°C	32 to 3100°F	±0.1% of F.S.
	N	10	-200.0 to 1300.0°C	-300.0 to 2400.0°F	
	E	11	-270.0 to 1000.0°C	-450.0 to 1800.0°F	0°C and over: ±0.1% of F.S.
	L	12	-200.0 to 900.0°C	-300.0 to 1600.0°F	Below 0°C : ±0.2% of F.S.
	U	13	-200.0 to 400.0°C	-300.0 to 750.0°F	E (below -200°C) : ±1.5% of F.S.
			0.0 to 400.0°C	-200.0 to 1000.0°F	±0.2% of F.S.
	W	15	0.0 to 2300.0°C	32 to 4200°F	±0.2% of F.S.
Platinel 2	16	0.0 to 1390.0°C	32.0 to 2500.0°F	±0.1% of F.S.	
PR20-40	17	0.0 to 1900.0°C	32 to 3400°F	800°C and over: ±0.5% of F.S. Below 800°C : Accuracy not guaranteed	
W97Re3 W75Re25	18	0.0 to 2000.0°C	32 to 3600°F	±0.2% of F.S.	
RTD	JPt100	30	-200.0 to 500.0°C	-300.0 to 1000.0°F	±0.1% of F.S.
		31	-150.00 to 150.00°C	-200.0 to 300.0°F	±0.2% of F.S.
	Pt100 (ITS90)	35	-200.0 to 850.0°C	-300.0 to 1560.0°F	±0.1% of F.S.
		36	-200.0 to 500.0°C	-300.0 to 1000.0°F	±0.2% of F.S.
37	-150.00 to 150.00°C	-200.0 to 300.0°F			
Standard signal	0.4 to 2.0 V	40	0.400 to 2.000	/	±0.1% of F.S.
	1 to 5 V	41	1.000 to 5.000		
DC voltage	0 to 2 V	50	0.000 to 2.000		
	0 to 10 V	51	0.00 to 10.00		
	-10 to 20mV	55	-10.00 to 20.00		
	0 to 100mV	56	0.0 to 100.0		

## ■ Communication Functions (Optional code: /A10)

- Communication port:
  - One port (communication terminals)
- Communication protocol:
  - MODBUS and PC-link communication
- Communication interface: One channel
  - Standard: EIA RS-485
  - Number of connectable units: Maximum of 31 units
  - Communication distance: Maximum of 1200 m
  - Communication method: Two-wire half-duplex or four-wire half-duplex, start-stop synchronization, and non-procedural communication.
  - Communication rate:
    - 600, 1200, 2400, 4800, 9600, 19200, 38400 bps

## ■ Optical Communication Part for Light Loader

This is used to set parameters and custom computation information from a personal computer using the optional LL1100 PC-based Parameters Setting Tool and the LL1200 PC-based Custom Computation Building Tool. (See also the GS 5G1A01-01E and GS 5G1A11-01E sheets.)

## ■ Operation upon Power Recovery

- Power failure of less than 2 seconds: The operation prior to power failure is resumed upon power recovery.
- Power failure of 2 seconds or more: The operation upon power recovery is selected by the restart mode setting. It is either set so that the operation prior to power failure is resumed, or so that operation starts in MAN mode.

## ■ Lamp/Display Status during Abnormalities

- System alarm: Error code display, or a flashing decimal point in the rightmost part of the PV digital display.
- Diagnostic alarm: ALM lamp is lit, and there is an error comment display and/or flashing decimal point.
- Process alarm: ALM lamp is lit, and the display is normal.
  - Others: ALM lamp is off, and there is an error comment display and/or flashing decimal point.

## ■ Hardware Specifications

### ● Input/Output Signal Specifications

\*The I/O accuracy under standard operating conditions (temperature:  $23 \pm 2^\circ\text{C}$ ; humidity:  $55 \pm 10\%$  RH; power supply frequency: 50/60 Hz), are as follows.

- **Analog input**
  - Number of input points: 1 or 2
  - Input type, range, and accuracy: Refer to the input table.
  - Sampling period: Control period

Burnout detection Thermocouple input: Input bias current  $0.05 \mu\text{A}$

RTD input: Input bias current  $0.05 \mu\text{A}$

Standard signal input: 0.1 V or less

Input resistance Thermocouple and mV input:  $1 \text{ M}\Omega$  or more

Standard signal and V input: Approx.  $1 \text{ M}\Omega$

Allowable signal source resistance

Thermocouple and mV input:  $250 \Omega$  or less

Standard signal and V input:  $2 \text{ k}\Omega$  or less

Signal source resistance effect

Thermocouple and mV input:  $0.1 \mu\text{V}/\Omega$  or less

Standard signal and V input:  $0.01\%/100 \Omega$

Allowable lead wire resistance

RTD input: Maximum of  $150 \Omega/\text{wire}$  (The resistance must be the same for all 3 wires.)

$10 \Omega/\text{wire}$  at  $-150$  to  $150^\circ\text{C}$

Allowable input voltage

Thermocouple, mV and RTD input:  $\pm 10 \text{ V DC}$

Standard signal and V input:  $\pm 20 \text{ V DC}$

Noise rejection ratio Normal mode:
 

- $40 \text{ dB}$  (50/60 Hz) or more
- Common mode:
  - $120 \text{ dB}$  (50/60 Hz) or more

Reference junction compensation error

Thermocouple input:  $\pm 1.0^\circ\text{C}$  (at  $15$  to  $35^\circ\text{C}$ ) and  $\pm 1.5^\circ\text{C}$  (at  $0$  to  $15^\circ\text{C}$  or  $35$  to  $50^\circ\text{C}$ )

Applicable standards Thermocouple and RTD: JIS / IEC / DIN

### • Analog input 3

Number of input point: 1

Input type: 2 types.....Standard signal input: 1 to 5 V  
.....DC voltage input: 0 to 10 V

Burnout detection:  $0.1 \text{ V}$  or less

Input accuracy: Standard signal and DC voltage input:  $\pm 0.2\%$  of input span

Input resistance: Standard signal and DC voltage input: Approx.  $1 \text{ M}\Omega$

Allowable signal source resistance:  $2 \text{ k}\Omega$  or less

Signal source resistance effect:  $0.01\%/100 \Omega$

Allowable input voltage:  $\pm 20 \text{ V DC}$

Sampling period: Control period (100 ms or more)

Noise rejection ratio Normal mode:
 

- $40 \text{ dB}$  (50/60 Hz) or more
- Common mode:
  - $120 \text{ dB}$  (50/60 Hz) or more

### • Feedback resistance input (US1000-21 only)

Number of input points: 1

Input type Slide wire resistance input with a total resistance of  $100 \Omega$  to  $2.5 \text{ k}\Omega$  (and slide-wire breakage detection)

Measuring resolution:
 

- $\pm 0.1\%$  of total resistance (After user's adjustment)

Measuring span resistance:
 

- Arbitrary within total resistance (After user's adjustment)

Sampling period: 50 ms

### • Loop power supply for transmitter

The Yokogawa BRAIN transmitter with communication function and the BRAIN terminal can be used.

Number of output points: 1 or 2  
Power supply voltage:  $25.5 \pm 1.5$  V DC (at 4 to 20 mA)  
Maximum supply current:  $30 \pm 5$  mA DC

### • MV output

Current output  
Number of output points 1 or 2  
Output signal  
4 to 20, 0 to 20, 20 to 4, or 20 to 0 mA DC  
(Signals less than 0 mA cannot be output.)  
Output accuracy  $\pm 0.3\%$  of span  
Load resistance  $600 \Omega$  or less  
Output ripple  $0.1\%$  of F.S.(p-p) or less at 300 Hz  
Voltage pulse output  
Number of output points 1 or 2  
Output signals  
12 V or more for ON voltage; 0.1 V DC or less for OFF voltage.  
Load resistance  
 $600 \Omega$  or more; short-circuit current is approx. 30 mA DC.  
Minimum pulse width  
10 ms or 0.1% of output, whichever is larger.

### • Relay contact output

Number of output points 1 or 2  
Output signals NC, NO, and common terminals.  
Contact rating 250 V AC, 3A at 30 V DC, 3A (resistance load).  
Resolution 10 ms or 0.1% of output, whichever is larger.  
Minimum output working time 20ms

### • Position proportional relay contact output (US1000-21 only)

Number of output points  
1 point made up of 2 contacts.  
Output signals  
H (direct rotation), L (reverse rotation), and common terminals.  
Contact rating  
250 V AC, 3A at 30 V DC, 3A (resistance load).

### • Retransmission Output

Number of output points 1  
Output signal 1 to 5, 0 to 5, 5 to 1, or 5 to 0 V DC  
(Signals below 0 V cannot be output.)  
Output accuracy  $\pm 0.3\%$  of span  
Load resistance  $2 \text{ k}\Omega$  or more  
Output ripple  $0.1\%$  of F.S.(p-p) or less at 300 Hz

### • Contact input

Number of input points 2 or 7  
Input type Non-voltage contact or transistor open collector  
Contact capacity 5 V DC at 20 mA or more  
Signal detection Non-voltage contact inputs are ON when the contact resistance is  $200 \Omega$  or less, and OFF when it is  $100 \text{ k}\Omega$  or more.  
Transistor open collector inputs are ON when voltage is 1 V DC or less, and OFF when leak current is  $100 \mu\text{A}$  or less.

Minimum pulse width

Three-times the control period

### • Contact output

Number of output points 3 or 7  
Output type Relay contact or transistor open collector  
Contact capacity  
Relay contact: 240 V AC, 1A at 30 V DC, 1A (resistance load)  
Transistor open collector:  
30 V DC, 200 mA (resistance load)

### ● Conformance to Safety and EMC standards

Safety standard:

- General safety standard requirements  
IEC1010-1: 1990  
EN61010-1: 1993

- Certified for CSA1010

The overvoltage category of each input is CAT II (IEC1010-1)

EMC standards:

During test, the controller continues to operate with the measurement accuracy within  $\pm 20\%$  of the range

EMI (Emission) EN55011: 1991, Class A, group 1  
EMS (immunity) EN50082-2: 1995

CSA standard:

Non-incendive electrical equipment for use in hazardous locations

CSA C22.2 No. 213:

Location Class I, division 2, Groups A, B, C, & D Temperature Code T4

### ● Construction, Installation, and Wiring (1, 2)

- Construction

Dust-proof and drip-proof (IP65): Front panel (drip-proof construction is not available when controllers are mounted closely side-by-side)

Material of the body:

(Modified polyphenylene-Ether Resin and polycarbonate)

Flame retardance grade:

Housing: V-0; bezel: V-2 or better

Color of housing: Munsell 0.8Y 2.5 / 0.4 (CC24)

External dimensions: 72 (W)  $\times$  144 (H)  $\times$  \*150 (D) mm

\* The depth dimension is from the mounting panel and does not include the terminal cover.

Weight: Approx. 800 g

- Mounting

Mounting: Direct panel mounting, fixed with upper and lower brackets

Mounting position: Inclined upward to a maximum of 30 degrees; not designed to be inclined downward.

Bracket tightening torque:  $0.2 \text{ N}\cdot\text{m}$  (2 kgf $\cdot$ cm) or less

Panel cutout dimensions:  $68^{+0.7}$  (W)  $\times$   $137^{+2.0}$  (H) mm

- Wiring

Terminals: M3.5 screws (at signal, power supply, and grounding terminals)

Terminal tightening torque:  $0.8 \text{ N}\cdot\text{m}$  (8 kgf $\cdot$ cm) or less

---

• **Power Supply and Isolation**

• Power supply

Rated voltage: 100 to 240 V AC to ( $\pm 10\%$ ), 50/60 Hz

Power consumption: 25 VA (11.0 W) at maximum

Allowable time for momentary power failure: 20 ms

Withstanding voltage:

Primary terminal  $\leftrightarrow$  secondary terminal: 1500 V AC (See Note) for 1 minute

Primary terminal  $\leftrightarrow$  grounding terminal:

1500 V AC (See Note) for 1 minute

Grounding terminal  $\leftrightarrow$  secondary terminal:

1500 V AC for 1 minute

Note: 2300 V AC for safety purposes.

Primary terminal:

Power supply and relay contact output terminals

Secondary terminal: Analog input/output, MV output, contact input, transistor open collector, and communication terminals

Isolation resistance Power supply terminal  $\leftrightarrow$  grounding terminal: 500 V DC at 20 M $\Omega$  or more

Grounding: Grounding resistance of no greater than 100 $\Omega$

External circuit-breaker rating:

Use a 5A circuit breaker (100/220V AC) in compliance with IEC947-1 or IEC947-3.

Installation in the same room as the US1000 is recommended.

• Isolation specifications

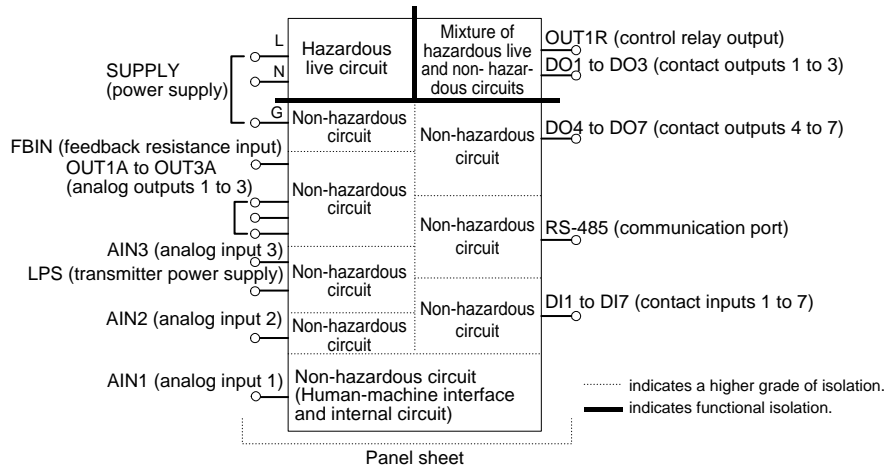

● Environmental Conditions

- Normal operating conditions
- Location: Indoor
- Warm-up time: 30 minutes or more
- Ambient temperature: 0 to 50°C  
(40°C or less for close side-by-side mounting)
- Temperature gradient: 10°C/h or less
- Ambient humidity: 5 to 90% RH (no condensation)
- Magnetic field: 400 AT/m or less
- Continuous vibration 5 to 14 Hz:

Peak-to-peak amplitude of 1.25 mm or less  
14 to 150 Hz: 4.9 m/s<sup>2</sup> (0.5G) or less

Short-period vibration

14.7 m/s<sup>2</sup> (1.5G) for no more than 15 s

Shock: 147 m/s<sup>2</sup> (15G) for no more than 11 ms

Installation height: Up to an altitude of 2,000 m (as per the heat radiation condition for equipment)

IEC1010 regulation: Installation category: II (See Note1.)

Pollution level: 2 (See Note2.)

Note1: The “Installation category” implies the regulation for impulse with stand voltage. It is also called the “Overvoltage category”, “II” applies to electrical equipment.

Note2: “Pollution level” describes the degree to which a solid, liquid or gas which deteriorates dielectric strength is adhering. “2” applies to a normal indoor atmosphere.

• Effects of operating conditions

Ambient temperature

Voltage and thermocouple input: ±1 μV/°C or ±0.01% of F.S./°C or less

RTD input: ±0.05°C/°C or less

Analog input 3: ±0.02% of F.S./°C or less

Analog output: ±0.05% of F.S./°C or less

Power supply (within rated voltage)

Analog input ±1 μV/10 V or ±0.01% of F.S./10 V or less

Analog output ±0.05% of F.S./10 V or less

• Transit and storage

Temperature: -25 to 70 °C

Temperature gradient: 20°C/h or less

Humidity: 5 to 95% RH (no condensation)

Shock: The controller does not experience shock effects if dropped less than 1 m.

■ Accessories

- A pair of mounting brackets
- Tag, unit, and numeral labels
- Terminal cover
- Operation manual
- Function manual

■ Items to be Specified at Ordering

- Model and suffix codes, option codes

## Function Diagram

This diagram is an excerpt from those of the control functions of the enhanced (with the suffix code "-11") US1000 controller.

For information on the function diagrams of the basic model (followed by the suffix code "-00") and position-proportional model (followed by the suffix code "-21"), see the *US1000 Digital Indicating Controller—Functions* instruction manual (IM 5D1A01-02E).

### Single-loop control

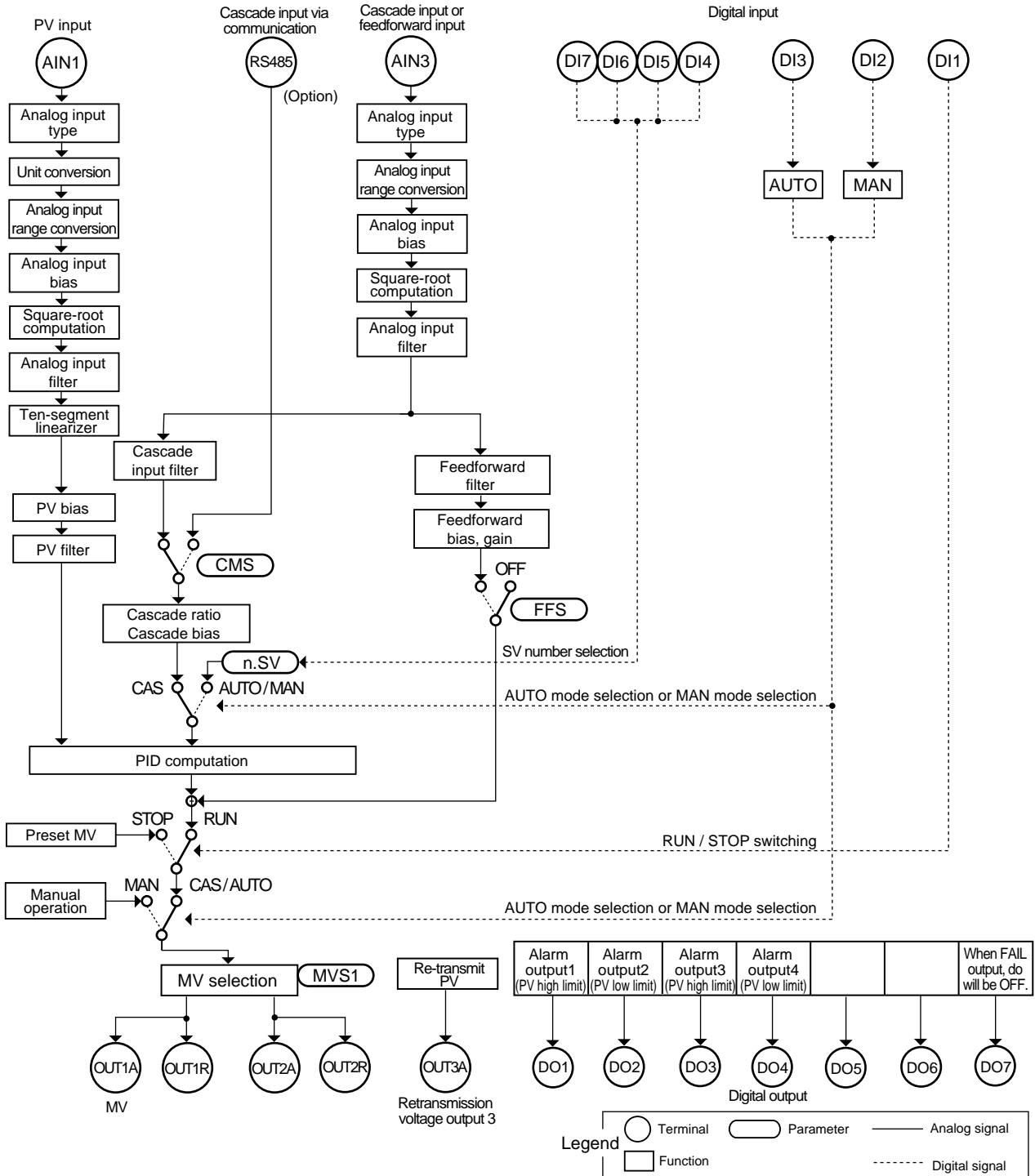

● Dual-loop control

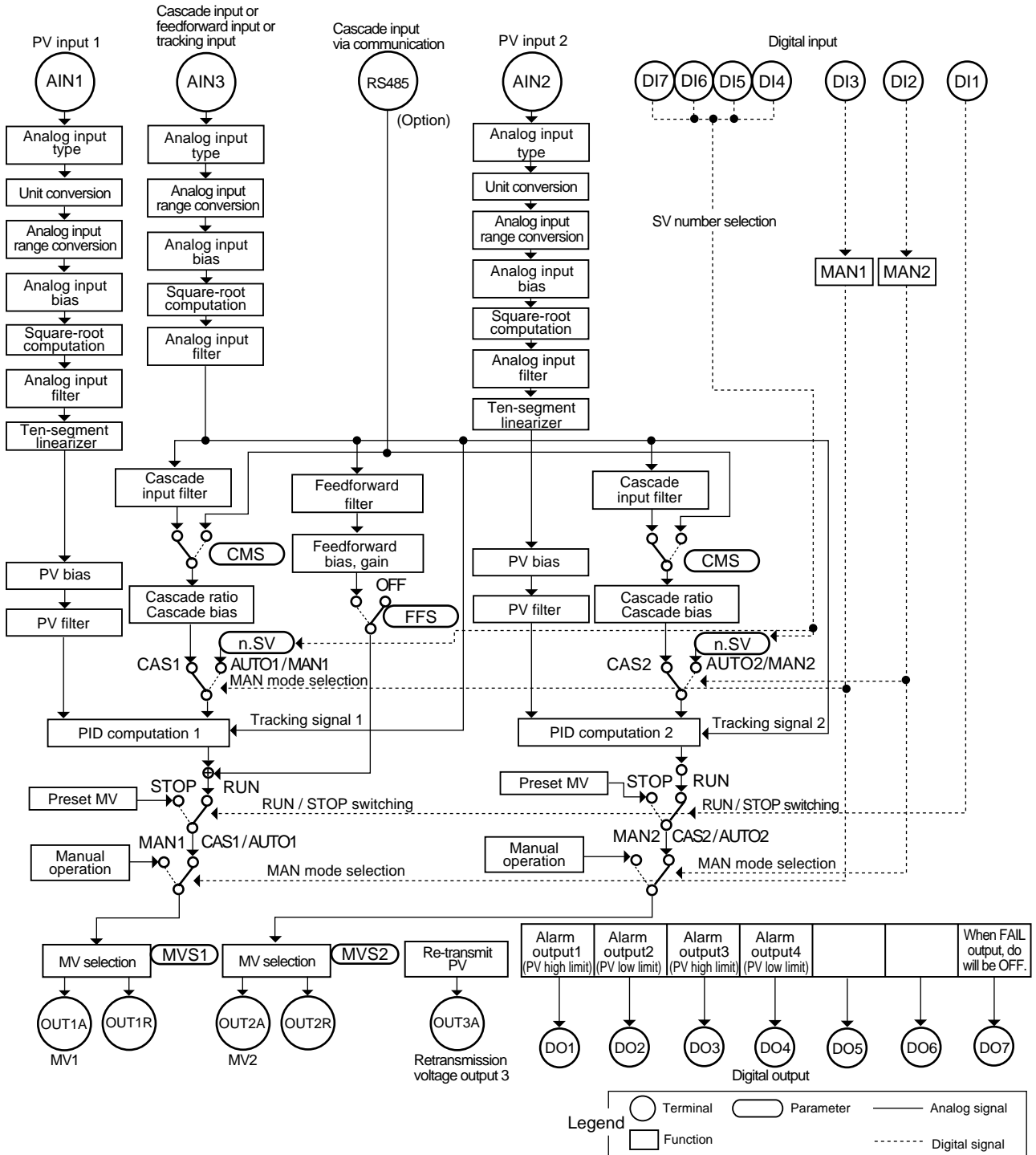

● Temperature and humidity control

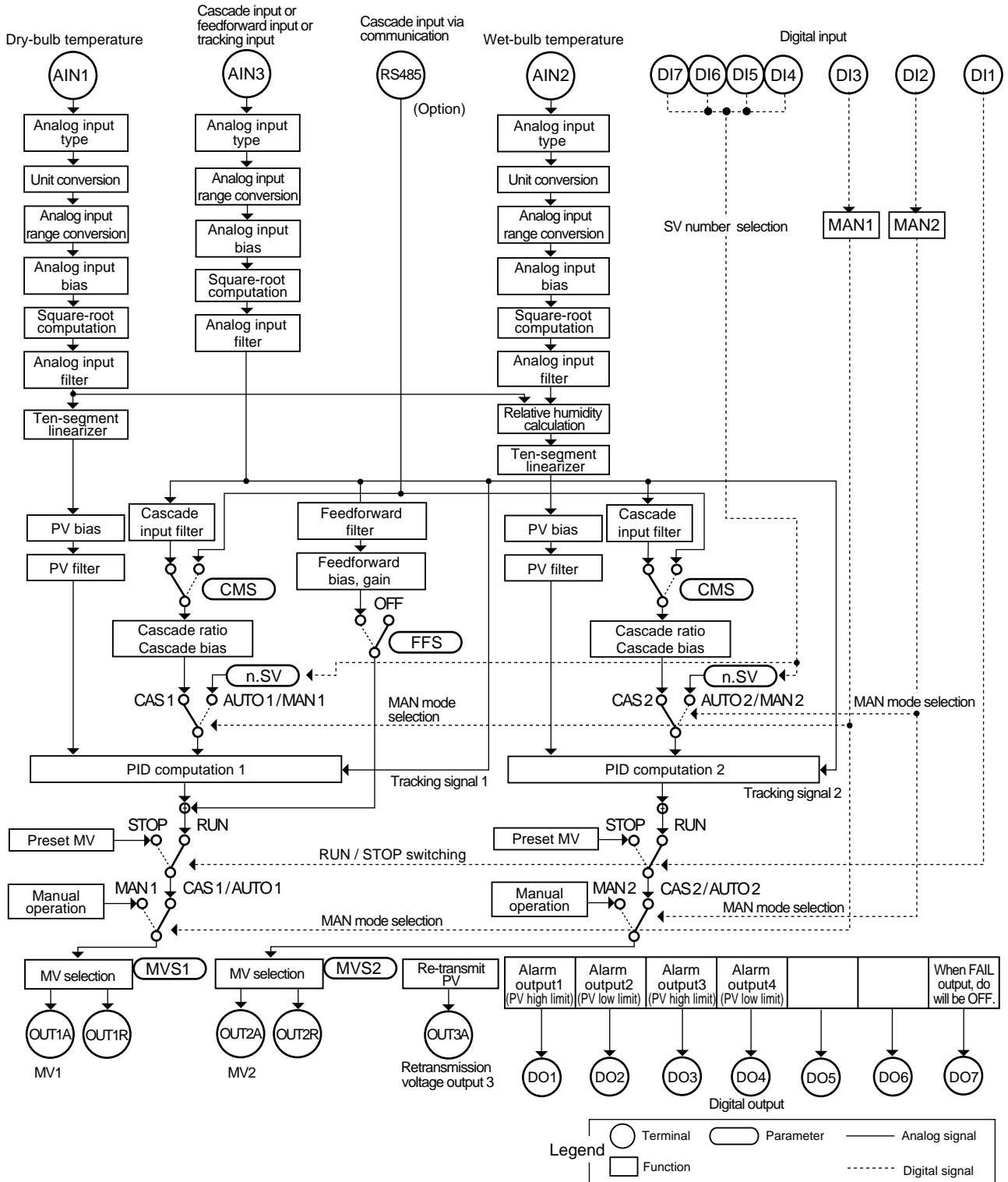

● Cascade control with two universal inputs

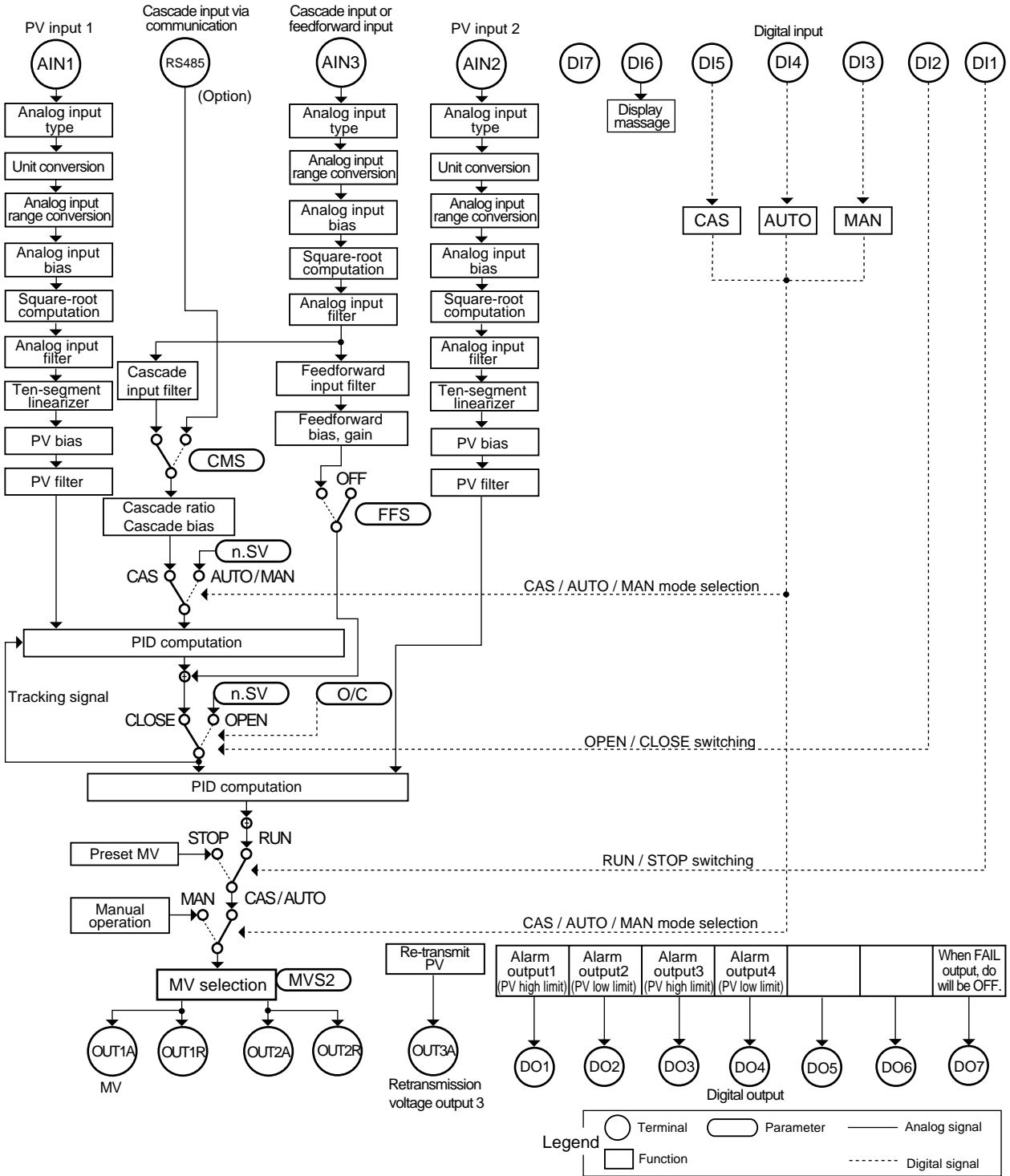

● Loop control with PV switching with two universal inputs

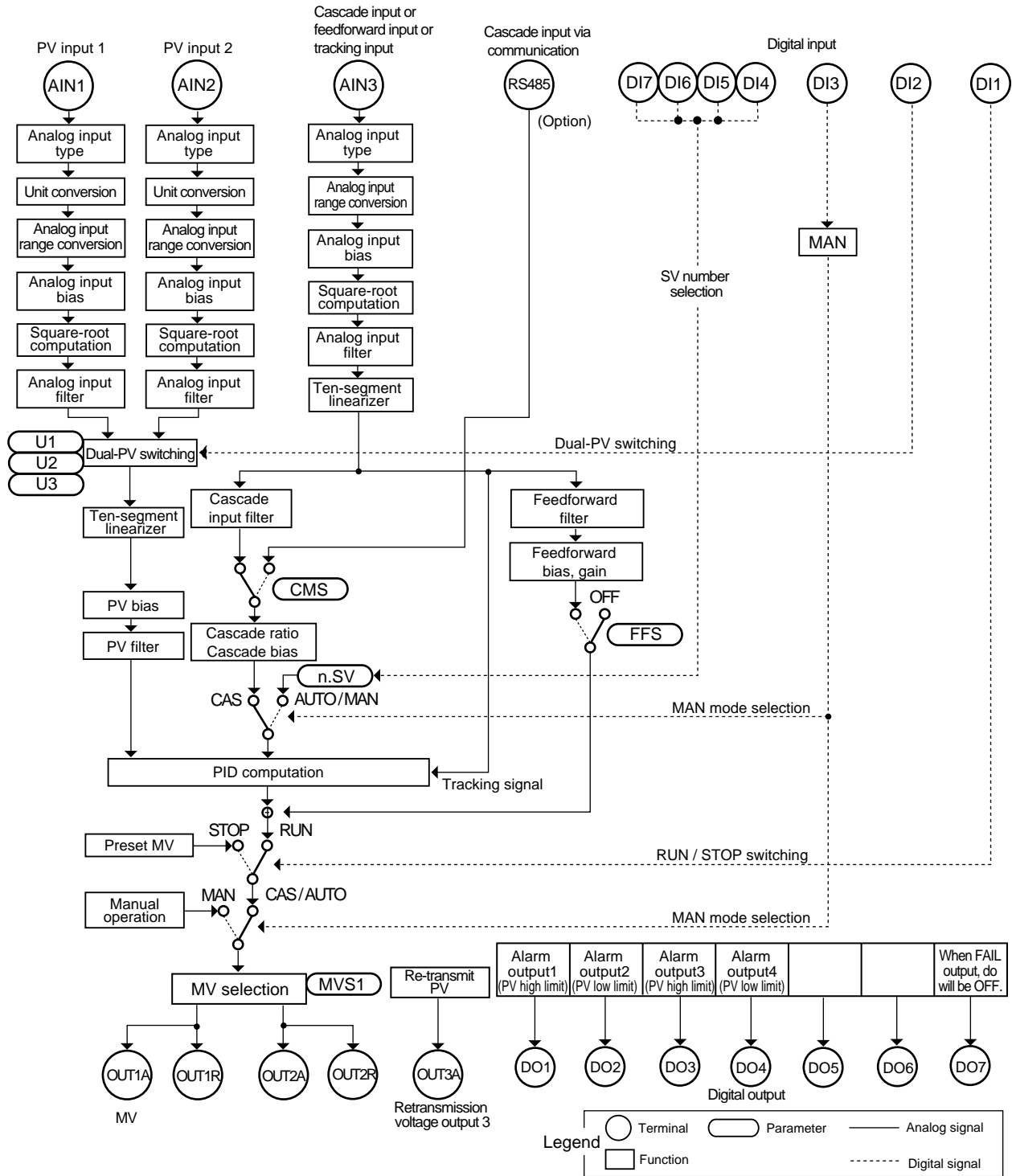

● Loop control with PV auto-selector with two universal inputs

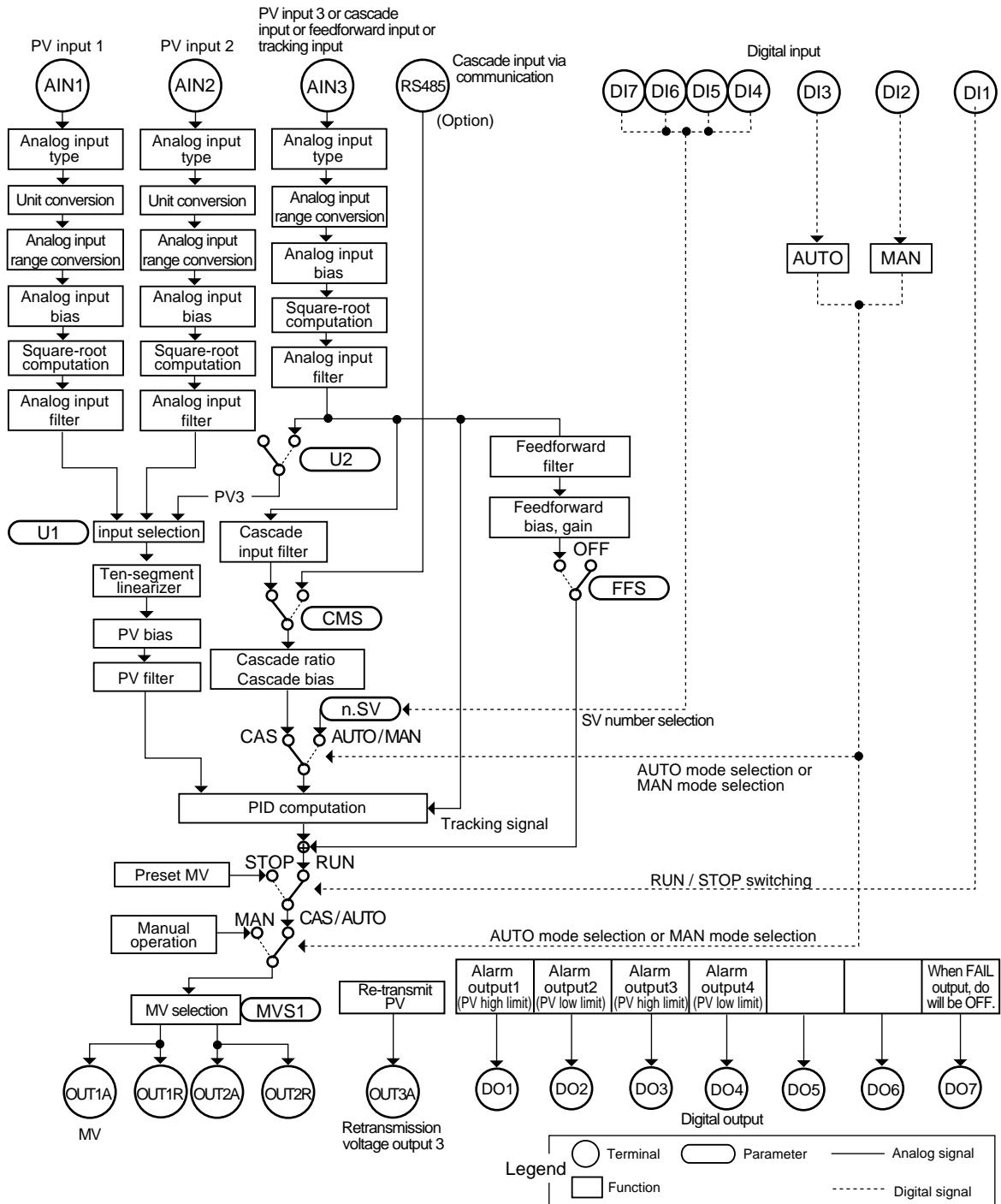

<Terminal layout>

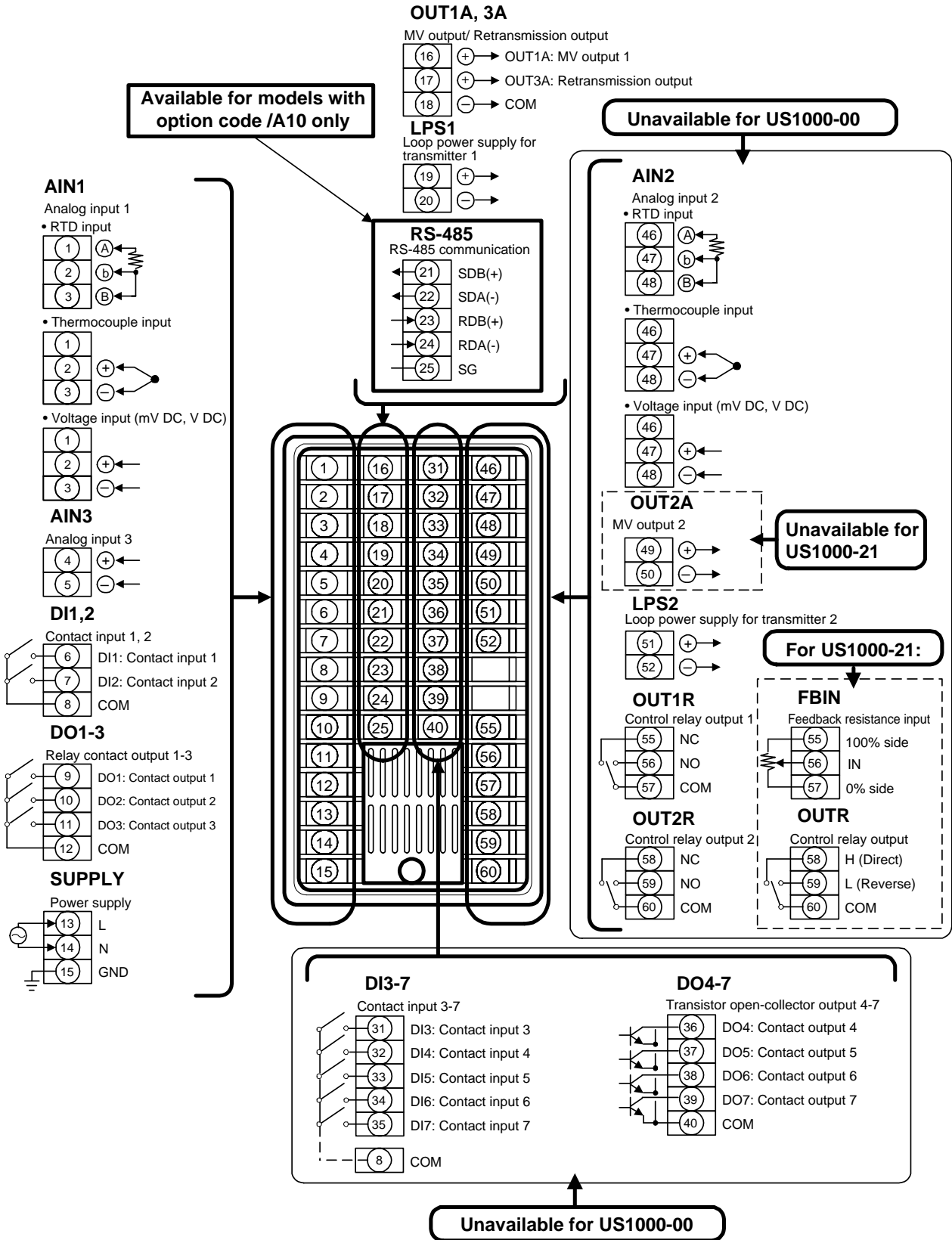

<Dimensions>

Unit: mm  
(approx. inch)

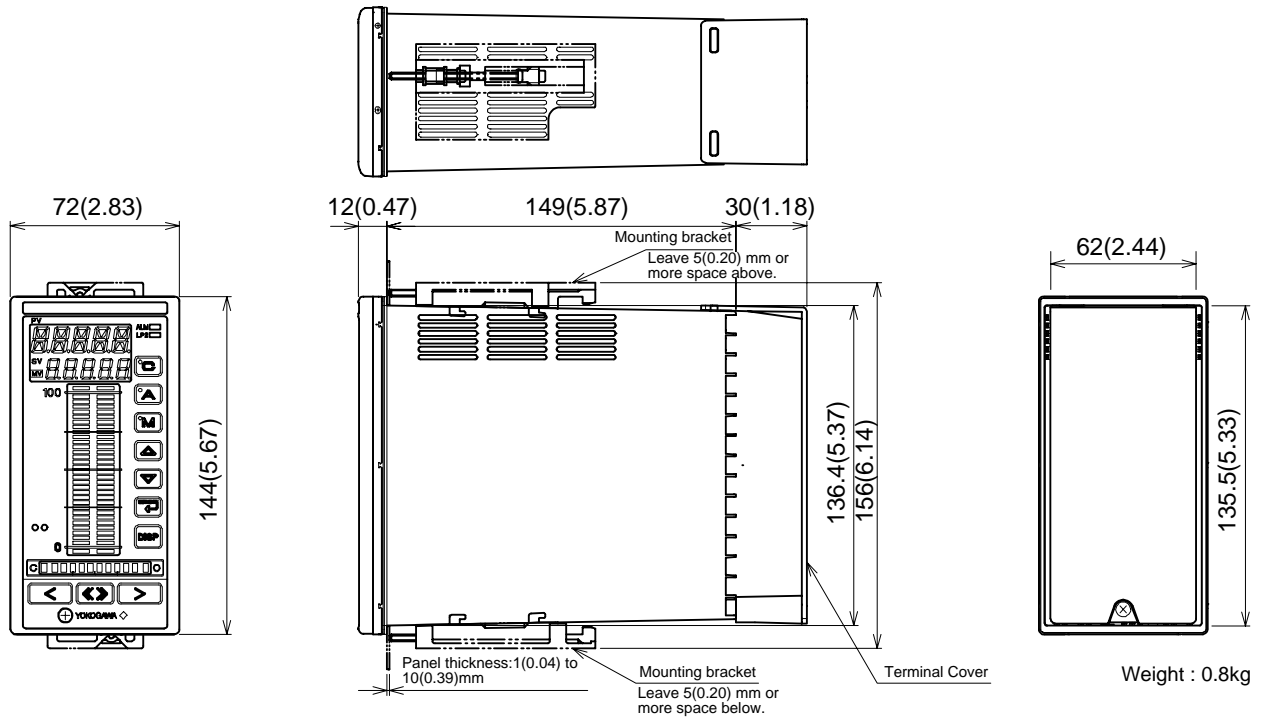

<Panel Cutout>

(General mounting)

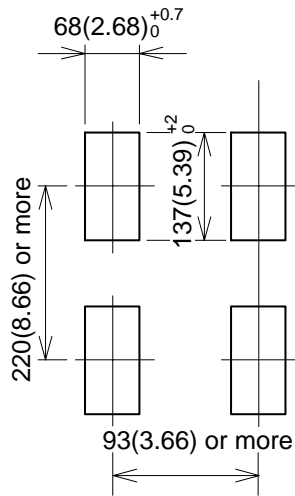

(Side-by-side close mounting)

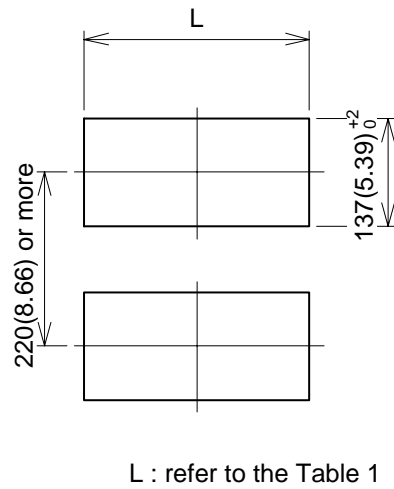

Panel cutout width for side-by-side close mounting [Table 1]

Number of units	L (mm)	L (inch)
2	140	5.51
3	212	8.35
4	284	11.18
5	356	14.02
6	428	16.85
7	500	19.69
8	572	22.52
9	644	25.35
10	716	28.19
11	788	31.02
12	860	33.86
13	932	36.69
14	1004	39.53